



KELCH

Tool presetters

High-performance, precise tool setting is essential when the highest degree of manufacturing precision and maximum efficiency of production resources are required.

We are convinced that you will find the most appropriate solution within our extensive range of **KENOVA set line** tool presetters. Tailored to every use and every budget.

KELCH can offer you the widest range of vertical tool presetters. The portfolio ranges from the simplest entry-level models through to machines with multiple CNC axes.

Are you looking for special applications? KELCH has them all. After all, it is precisely special solutions for out of the ordinary measuring tasks that differentiate a supplier of expertise.

For example, our patented module monitoring system MoDetec automatically monitors whether the fitted insert module is the correct one for the adapter chosen in the control. It is now impossible to use an incorrect insert module! And as reference values are immediately available, there is instant assignment to adapters, machines and tools.



Why KELCH?

One important point plays a key role time and time again in the design and development of tool presetters: the use of the optimum material.

Two components require particular attention in this – the guide rails and the spindle. Both the guide rails and also the spindle are made of **hardened steel**. Soft metals cannot be used for this purpose. The use of other materials for the basic body, tower and connecting parts results in a mix of materials – a result that it is critical to avoid.

This table clearly shows the differences in the material and its corresponding behaviour when exposed to temperature fluctuations.

	Coefficient of linear expansion $X \times 10^{-6}$	Linear expansion (Object length = 600 mm)	
		$\Delta T = 1 \text{ K}$	$\Delta T = 10 \text{ K}$
Aluminium	~ 23	~ 600.014	~ 600.140
Granite	~ 3	~ 600.004	~ 600.020
Grey cast iron*	~ 12	~ 600.007	~ 600.070
Mineral cast*	~ 12	~ 600.007	~ 600.070
Steel*	~ 12	~ 600.007	~ 600.070

Representation of the linear expansion of different materials at a temperature expansion of 1 or 10 Kelvin.

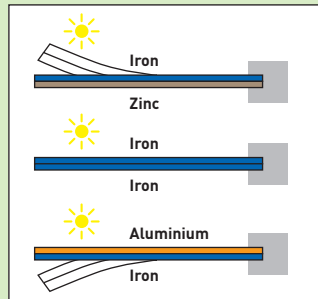

Illustration of the bimetal effect when exposed to temperature fluctuations

In many companies, tool presetters are not installed in air-conditioned rooms, therefore temperature differences of 10 °C are quite normal (Summer: approx. 17 °C in the morning – approx. 27 °C in the afternoon). This means that a 600 mm long object made of aluminium expands by 0.140 mm with a temperature rise of 10 °C. The combination of steel and aluminium (guide rails and spindle on an aluminium basic body) therefore generates a bimetal effect and distorts the entire geometry. When you compare the materials, admittedly granite has the lowest coefficient of expansion and, at first glance, looks the best. However, when you consider its bimetal effect, even granite is not ideally suitable. Materials with similar or identical coefficients of linear expansion are therefore most suitable.

KELCH has therefore always relied on the use of grey cast iron for an optimum material mix. The mix of the mineral cast composite used in the new KENOVA set line V9 and V9-S range is specifically tailored to the required material properties.

Our tool presetters therefore guarantee reliable geometric alignment with a reliable zero point that does not “shift” in the event of fluctuating temperatures. If unsuitable materials are used, then this zero point shift always needs to be compensated for by calibrating the system.

We don't save on material and use only high-quality materials to offer your a reliable and durable product.



KELCH's “Made in Germany” label could also be called “Made in Weinstadt” – right in the heart of the German mechanical engineering centre.

After all, the quality that satisfies our customers is made right here in Weinstadt. From machining the castings [basic body for the X-axis, tower, camera bracket] to grinding and production of the individual spindle components – everything comes from our factory. Even the spindle inserts and adapters responsible for the quality and repeatability of the measuring and presetting procedures are manufactured in Weinstadt by KELCH.

In doing so, we work closely with leading, well-known German manufacturers, including Heidenhain, Festo or Bosch. The high-precision telecentric optics of the tool presetters were developed solely for KELCH in conjunction with a premium German lens manufacturer.

And, of course, the units are also assembled in Weinstadt. A special service we offer is supervision of the preliminary handover of your new equipment at our premises. See “Made in Germany” quality for yourself on a guided tour through our production and assembly plants.

* used at KELCH



Table of contents

Why KELCH?	3	Tailstock	25
INDUSTRIAL line	6	Accessories for the PREMIUM line	2
KENOVA set line V3xx	6		
Accessories for the V3xx.....	8		
KENOVA set line H343	10	Software	27
Accessories for the H343.....	12	KELCH CoVis	28
		EASY	29
PREMIUM line	13	KELCH EASY – Angle heads.....	32
KENOVA set line V6xx	13	3D wizard	32
KENOVA set line V9xx/V9xx-S..	15	Contour software	33
Modular precision spindle	19	KELCH software interfaces.....	34
MoDetec (ModuleDetection)	20		
Turning centre camera	21	KELCH-Service	35
Grinding camera	21	Smart Factory Services	35
Tool identification.....	22	KELCH IoT solution	38
Laser pointer	22	KELCH Service	40
Rear clamping monitor.....	23		
Release mechanism	24	Technical data.....	42
Length adjustment.....	24	INDUSTRIAL line.....	42
Monitor combinations.....	25	PREMIUM line	44

INDUSTRIAL line

KENOVA set line V3xx





KENOVA set line V3xx with system underbench unit **TUL rack V**



Control panel for spindle functions

KENOVA set line V3xx

Ready for Industry 4.0 – The innovative and solid mid-class unit with a host of expansion levels and options for Smart Factory and IoT.

KELCH is expanding its INDUSTRIAL line with an Industry 4.0-compatible tool presetter for semi-automated or fully automated applications. The new range features EASY software, which can be operated without programming knowledge and integrated into automated processes and networked production systems.

Technical data

- | | |
|-----------------------------------|--|
| Construction: | · Compact grey cast iron design for use in the most confined spaces. |
| Positioning: | · Convenient positioning of the axes by pneumatically released quick adjustment mechanism
· Available in three versions: Manual, Autofocus, Fully CNC
· Additional fine adjustment:
a) Manual and Autofocus using handwheels
b) Fully CNC: fine adjustment of the 3 axes using a virtual control panel |
| Tool holder: | · High-precision tool spindle with direct SK 50 interface and integrated calibration balls.
Optionally with pneumatic tool clamping. |
| Cutting edge scanning: | · CMOS camera with telecentric optics and lighting for $\pm 2 \mu\text{m}$ repeatability. |
| Electronic measurement equipment: | · PC electronics with intelligent image processing
· 24" TFT monitor, 10" monitor on camera carrier (optional) |
| Measuring ranges: | · Longitudinal axis X (\emptyset) = -100 mm to 400 mm
Optional -100 mm to 600 mm
· Transverse axis Z = 600 mm |

Accessories for V3xx

Add to your tool presetter to meet your needs and requirements and customise it with our accessories.



TUL Rack V, closed

- Stable base with 3 compartments
- For the storage of PC electronics, adapters and other accessories, like printer, tools etc.
- Required space: L x W x H = 1730 x 1158 x 1158 mm



Illustrated example

Height-adjustable TUL workbench with plywood worktop

- Complete with a sheet steel shelf (250 mm deep)
- Colour: RAL 7035 Light grey
- Required space: L x W x H = 1500 x 700 x 740 to 1040 mm
- Load-bearing capacity: 1000 kg

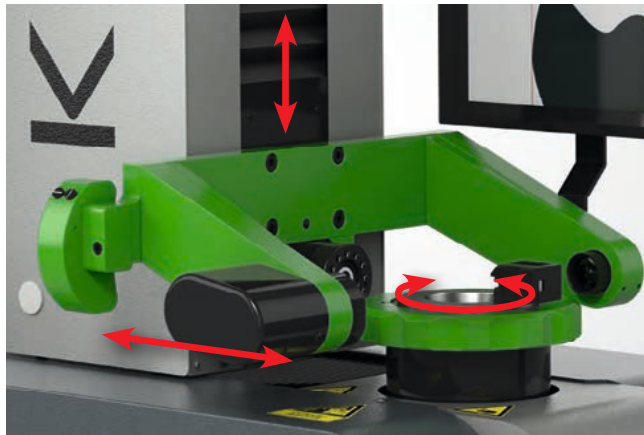

Autofocus / CNC

- The axes (C, X, Z) can optionally be motor-actuated for automatic measuring processes
- Equally feasible – Autofocus only: automatic focus and automatic processes for multi-edged tools



Turning centre camera

- Convenient control and setting of the turning centre with adjustable tools
- Additional CMOS camera with lens and LED ring light

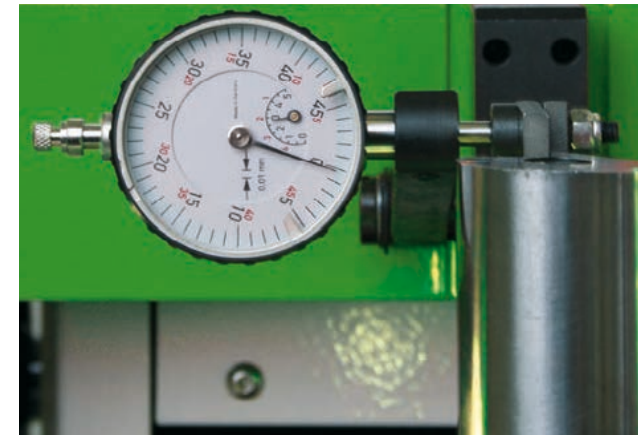

Turning centre measuring equipment

- Quality dial gauge, which can be swivelled in and out, for measurement of the turning centre, measuring range ± 2.5 mm, resolution 1 / 100 mm



Additional tool monitor

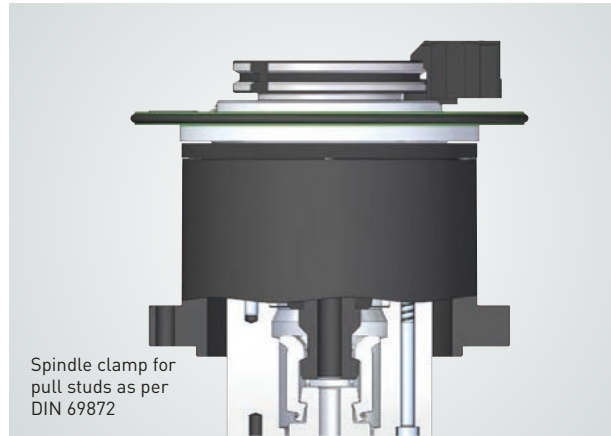

Spindle clamp for pull studs as per DIN 69872

Tool clamping

- Mechanical tool clamping in the spindle, as in the machine tool. The tools are positioned in the spindle with a minimum clamping force of 4 kN for precise repeat measurements.



RFID system

- Manual tool identification
- Up to 2 read-write heads can be connected
- For RFID chips on the tool collar and in the pull stud



Reducers

- Adapters to hold different tool tapers or cylinders in the SK 50 tool holder spindle.
- Available for all common interfaces such as: SK/HSK/PSC/VDI.
- Also available in an automatic design.



Label printer

- Thermo-label printer



Illustrated example

Protective cover for V3xx units

- Protects from dust and dirt

INDUSTRIAL line

KENOVA set line H343

Video

Simply scan the QR code with your smartphone and view the video.

<https://youtu.be/2sH0dNJvmVo>





Fine adjustment in both axes
For μm -precise fine adjustment in the X and Z direction.

Table layout
Versatile table layouts with tool holders and spindle.

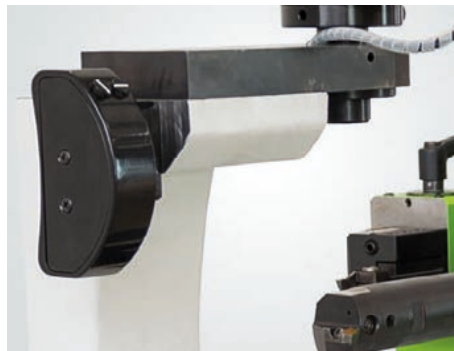

Operating panel for spindle function
Ergonomically ideal position and including all spindle operating elements.

Ergonomic handle
Quick adjustment of the axes ensures ergonomic working.



EASY software (optionally CoVis)

Optional optics carrier with turning centre camera

KENOVA set line H343

The new compact entry-level tool presetter for horizontal tool measurement.

Thanks to its compact design, the horizontal tool presetter is ideal for small and medium-sized businesses. Do you have a clear need for tool measurement and require a stable and precise measuring system? KELCH offers this option with the innovative development of the KENOVA set line H343. A further benefit includes possible connection to tool management systems. The unit is therefore suitable for use with Industry 4.0 applications.

Technical data

- Compact grey cast iron design for use in the most confined spaces.
- Convenient positioning of the axes by pneumatically released quick adjustment mechanism and also endless fine adjustment.
- Measuring ranges: Longitudinal axis X (\emptyset) = 400 mm
Transverse axis Z = 300 mm
- Versatile table layouts with tool holders with diverse interfaces (VDI, HSK, PSC, Index etc.), manual modular precision spindle, universal tool spindle and customised fixings.
- Telecentric optics, lighting and CCD camera with various control and evaluation programs: CoVis and EASY.

Accessories for the H343

Add to your tool presetter to meet your needs and requirements and customise it with our accessories.

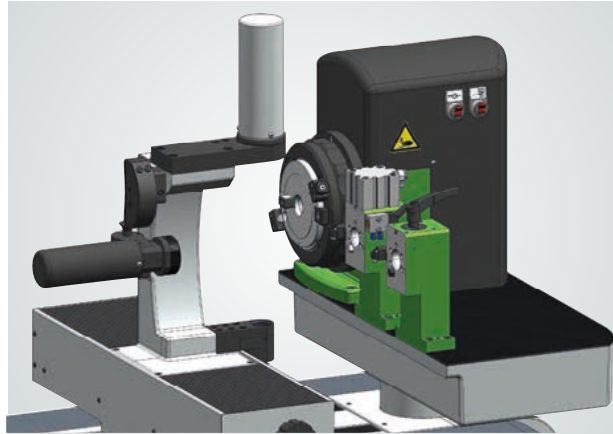

Table layout

- Example of a possible table layout



Label printer

- Thermo-label printer



Illustrated
example

Protective cover for H343 unit

- Protects from dust and dirt



PREMIUM line

KENOVA set line V6xx



Video

Simply scan the QR code with your smartphone and view the video.

<https://youtu.be/uFqHAftjZzs>



KENOVA set line V6xx

The new compact premium tool presetter for maximum precision in the most compact spaces.

The KENOVA set line V6 series guarantees fast, easy and precise measurements coupled with maximum possible process reliability from patented systems. The compact PREMIUM line system can be integrated very easily into an ergonomic workplace design, leaving plenty of space for tools and materials.

Technical data

- Construction:**
- Compact grey cast iron design for use in the most confined spaces.
- Positioning:**
- Convenient positioning of the axes by pneumatically released quick adjustment mechanism
 - Additional fine adjustment:
 - a) Manual and Autofocus using handwheels
 - b) Fully CNC: joystick fine adjustment of the 3 axes
- Tool holder:**
- Modular precision spindle to accommodate diverse SK, HSK, PSC, VDI etc. inserts.
 - Positional fixing:
 - a) Manual: by mechanical clamp and brake
 - b) Autofocus / CNC: by a coupling
- Cutting edge scanning:**
- CCD camera with telecentric lens and top light for $\pm 2 \mu\text{m}$ repeatability
 - Optional: optical turning centre measuring equipment
 - S-camera for tool grinders
 - Probe for cutting edges difficult to access
- Electronic measurement equipment:**
- PC electronics with intelligent image processing
 - 24" TFT monitor, 10" monitor on camera carrier (optional)
- Measuring ranges:**
- Longitudinal axis X (\emptyset) = -100 to 430 mm
optionally -220 to 310 mm
 - Transverse axis Z = 600 / 800 / 1000 mm

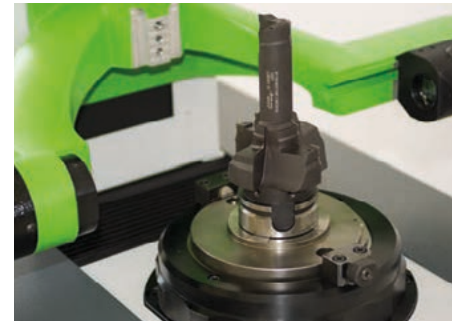

Modular precision spindle the most stable and precise tool holder spindle.



Control panel with joystick to move the CNC axes.



Optics carrier including CCD camera and pneumatic quick adjustment. Optional laser pointer for detection of the cutting edge.



TUL Rack V, closed

- Stable base with 3 compartments
- L x W x H = 1730 x 1158 x 1158 mm

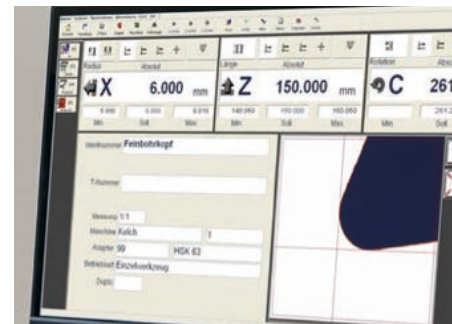

EASY software intuitively operated.

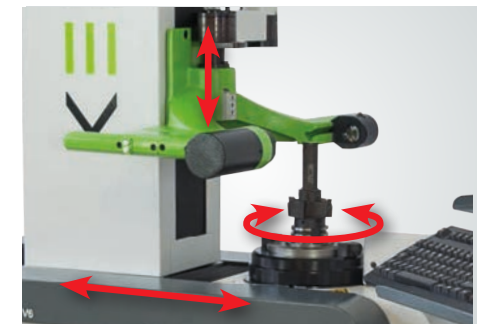

Autofocus / CNC

- The axes (C, X, Z) can optionally be motor-actuated for automatic measuring processes
- Equally feasible – Autofocus only



PREMIUM line

KENOVA set line V9xx / V9xx-S

Video

Simply scan the QR code with your smartphone and view the video.

<https://youtu.be/5w4z206T-qQ>



BLUECOMPETENCE

Alliance Member



KENOVA set line V9xx

The revolution in tool presetting.

Ease of use coupled with maximum precision. This range is modern, ergonomically designed and unique in its design. With its mineral cast base, cast in one piece from the guideway to the floor, KELCH is setting new benchmarks in the design of tool presetters. This design promises durable and consistent mechanical KELCH quality.

Product features of mineral cast:

- Environmentally-friendly manufacture thanks to cold casting process
- Sustainable recycling is possible
- Vibration-damping
- Insensitive to temperature fluctuations thanks to thermal inertia
- Precise measurement due to robust structure

Technical data

- | | |
|-----------------------------------|---|
| Construction: | <ul style="list-style-type: none"> · Fully CNC tool presetter · Thermally stable and vibration-dampening mineral cast composite base · Excellent load-bearing capacity and stability |
| Drive: | <ul style="list-style-type: none"> · 3 axes, CNC · Optional: 4th axis for automatic length adjustment |
| Cutting edge scanning: | <ul style="list-style-type: none"> · CCD camera with telecentric lens and top light · Optional: optical turning centre measuring equipment · S-camera for tool grinders · Probe for cutting edges difficult to access |
| Electronic measurement equipment: | <ul style="list-style-type: none"> · PC electronics with intelligent image processing · 24" TFT monitor, 10" monitor on camera carrier (optional) |
| Tool holder: | <ul style="list-style-type: none"> · Modular precision CNC spindle · Inserts for all common tool holders |
| Measuring ranges: | <ul style="list-style-type: none"> · Longitudinal axis X (\emptyset) = -100 to 530 / 830 / 1030 mm
optionally -220 to 410 / 710 / 910 mm · Transverse axis Z = 600 / 800 / 1000 / 1200 mm |



One-hand operation

The selective quick adjustment of the axes has always been standard at KELCH. The axis clamp can be released quickly and easily and the cutting edge comes into focus.



Precise optics

Telecentric measuring lens for the ultimate in precision. Opt. laser pointer integrated in the camera arm for visual detection of the cutting edge.



Control panel

All operating elements integrated: spindle clamp, tool clamping system and joystick to move the axes.

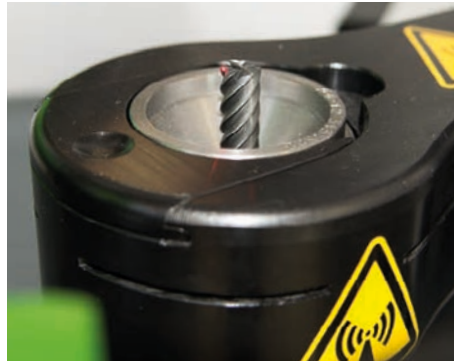
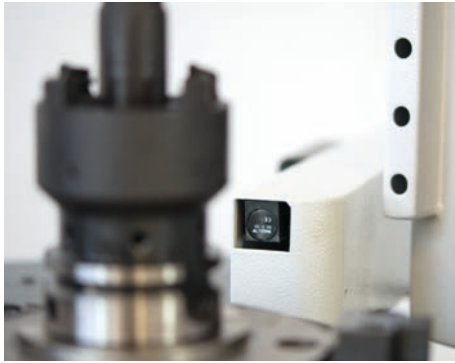

Optional: Tool identification

Automated and error-free importing and exporting of tool data.

Shrink coil in action

Position of the shrink coil during shrinking.



Shrink fit equipment

The accessories are ergonomically positioned in front of the shrink fit equipment with the coil.

KENOVA set line V9xx / V9xx-S

Precise shrinking and setting in one unit.

Shrink grip and shrink release, measurement and presetting – the KENOVA set line V9xx-S offers all this and more. A tool presetter combined with an inductive shrink fit device.

Dynamics and flexibility in one.

KENOVA set line V9xx-S combines the KENOVA set line V9xx tool presetter and the i-tec® M shrink fit device to create an automatic station. The KENOVA set line V9xx-S enables tools to be perfectly measured, pre-set and simultaneously shrunk on one device. A unique feature of the dynamic shrink fit process is the fact that tools can be very quickly shrunk and adjusted to the required target dimension.

Dynamic presetting

In the phase in which the chuck is opened by warming, the tool is set exactly to its target length fully automatically. The benefits of this process include the short cycle times and the option of changing the tool in a single cycle. Naturally chucks from different “quality manufacturers” can also be used here.

Presetting

If measurements are necessary, which do not permit setting during the expansion phase of the chuck, the length of the shank tool is determined using setting adaptors prior to heating. The tool is finally shrunk to its target length using intelligent calculation and pre-positioning of the setting pins. This process is mainly designed for complex measuring tasks or for HSS tools.

High-end tool presetter with integrated induction coil for automatic shrinking with length adjustment.

Technical data – KENOVA set line V9xx-S

- | | |
|-----------------------------------|---|
| Construction: | <ul style="list-style-type: none"> · Fully CNC tool presetter and shrink fit device · Thermally stable and vibration-dampening mineral cast composite base · Excellent load-bearing capacity and stability |
| Drive: | <ul style="list-style-type: none"> · 5 automatic axes, 4 of which designed as CNC axes |
| Cutting edge scanning: | <ul style="list-style-type: none"> · CCD camera with telecentric lens and top light · Optional: optical turning centre measuring equipment · S-camera for tool grinders · Probe for cutting edges difficult to access |
| Electronic measurement equipment: | <ul style="list-style-type: none"> · PC electronics with intelligent image processing · 24" TFT monitor · 10" TFT monitor on camera carrier (optional) |
| Tool holder: | <ul style="list-style-type: none"> · Modular precision CNC spindle · Inserts for all common tool holders |
| Measuring ranges: | <ul style="list-style-type: none"> · Longitudinal axis X (\emptyset) = -100 to 530 mm*
optionally -220 to 410 mm* · Transverse axis Z = 600 / 800 mm |
| Shrinking: | <ul style="list-style-type: none"> · Automatically movable induction coil · For HSS and carbide · Optional: Smoke removal extraction system |
| Cooling: | <ul style="list-style-type: none"> · Separate cooling station, completely decoupled from the thermally critical presetting part; simultaneous cooling of 3 shrink chucks · Contact cooling with cooling adapters through which water flows and modular inserts · Cooling time about 60 seconds |

* max. \emptyset 440 mm pivotable due to shrink fit equipment



Side unit

Compact design with various storage options.



Worktop of side unit

Ergonomically arranged cooling sockets and adapters with tool and setting pins.

The integrated CNC-measuring station fulfils the most exacting demands placed on measuring tasks and measuring results.

Unique performance features:

- Solid measuring device on a single block mineral cast base; also available as a seated or accessible workstation
- CNC control in up to 4 axes, also manually operable for quick measuring, even without reference data
- Automatic axis process by powerful servo motors for high-precision positioning of the axes
- Flexible installation of space-optimised peripheral equipment with height-adjustable monitor plate for a user-friendly working environment
- Compact storage of all accessories, such as monitor, keyboard, printer and adaptor, makes work easier
- The computer and electronics are tidily accommodated and easy to access in the spacious switch cabinet
- Workshop-compatible and durable with an industrial PC for measurement control
- Individually adaptable to all measuring tasks and data flows
- Drawer for storage of tools and other ancillary materials



Inserts for the modular precision spindle

The contact face and the short taper ensure maximum repeatability when changing the insert modules, available for all standard HSK, PSC, VDI, KM and SK tool holders. Clamping for all tools is similar to the machine tool, with steep taper holders using retention knobs centrally from behind and HSK holders using original clamping units expanded from the inside.

Clamping forces:	SK/BT	up to 5 kN
	HSK	up to 15 kN
	PSC	up to 25 kN

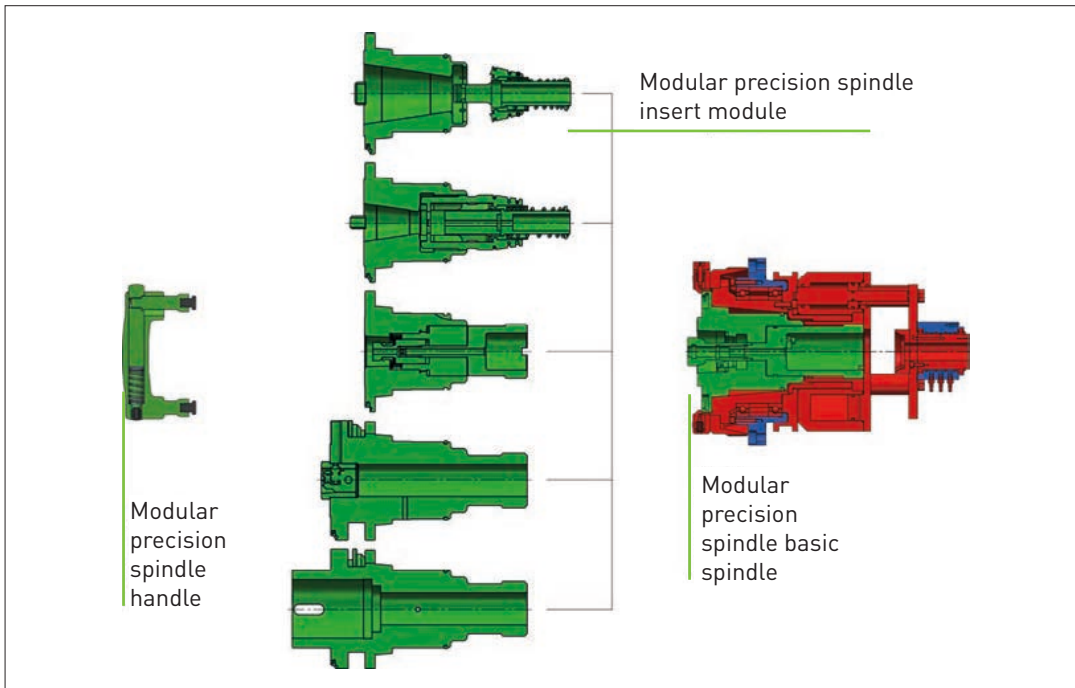

Modular precision spindle

The world's best spindle for PREMIUM line tool presetters:
KENOVA set line V6xx, V9xx and H343

- Basic spindle run-out ≤ 0.001 mm
- Change precision of insert modules ≤ 0.001 mm
- No loss of measuring path in the Z axis
- Tool weight of up to 100 kg (KENOVA set line V6xx) / 150 kg (KENOVA set line V9xx)

Features

KELCH's own modular precision spindle is the most stable and precise tool holder spindle you can find. Decades of experience coupled with outstanding engineering knowledge and expertise lie behind this ultra-precise spindle. The modular system enables spindle inserts to be swapped within less than five seconds while maintaining excellent precision. Maximum run-out of $1 \mu\text{m}$ on the flat surface and $< 3 \mu\text{m}$ at a height of 300 mm and a tool weight of up to 150 kg speak for themselves.

MoDetec (ModuleDetection)

Scenario

The right spindle insert must be selected before measuring the tools when using different spindle inserts (e.g. SK 50, HSK 63, PSC 50 etc.), as the zero point of the tool presetter is dependent on this. If you wish to measure an SK 50 tool but have forgotten to change from HSK 63 to SK 50 in the software, the system assumes a different zero point. This leads to incorrect measured values and thus to poor results on the workpiece. There is also the possible threat of collisions and damage in the machine.

Solution

The solution to this problem is provided by KELCH MoDetec. This patented system offers maximum process reliability, as the spindle insert communicates directly with the spindle and the software. As soon as the spindle insert is positioned in the basic spindle, the system detects the insert used and automatically selects the right insert in the software. Operating errors are thus a thing of the past.



Available for all equipment with modular precision spindle.



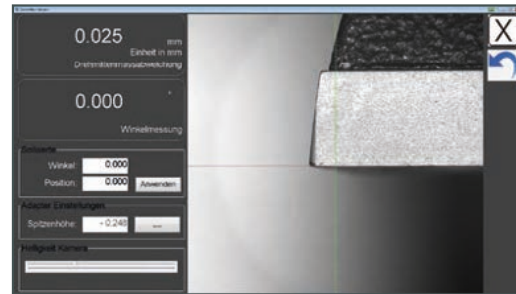
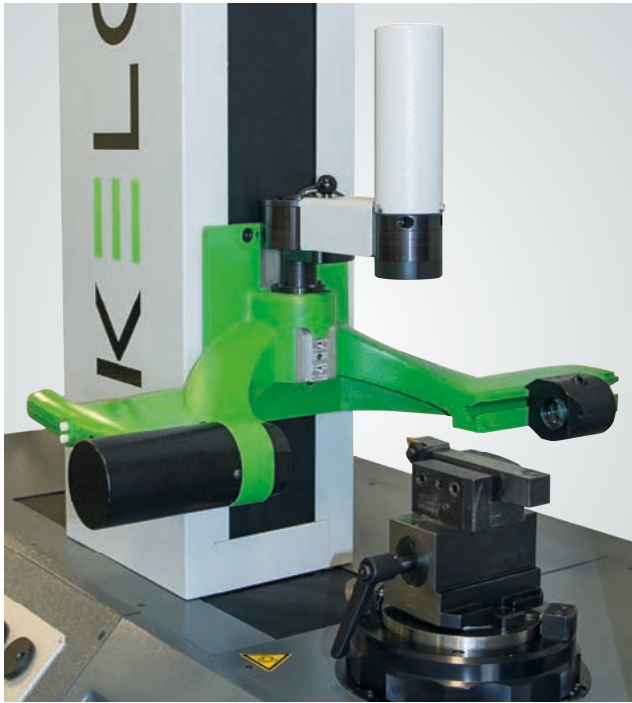

Turning centre camera

Features

- Additional CCD camera with telecentric lens and LED ring light
- Convenient control and setting of the turning centre with adjustable tools
- Adjustable tool inspection of the face geometry
- Swivels in and out

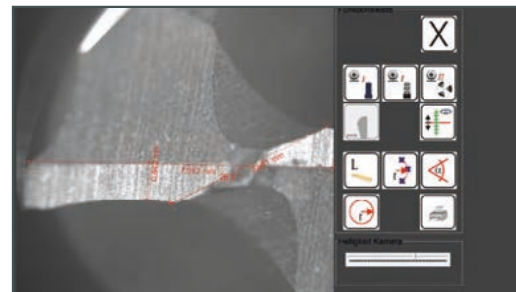

Grinding camera

Features

- Additional CCD camera with telecentric lens and LED ring light
- Convenient control and setting of the turning centre with adjustable tools
- Swivels from -90° to $+90^\circ$
- Additional tool inspection of the face and circumferential geometry
- Ideal for tool cutters to monitor the chamfer cut on the face and circumference
- Additional software options for manual reflected light measurement of radii, lengths and angles

Tool identification

Features

- Hardware and software for reading and writing RFID chips
- Manual or automatic
- Up to 2 read-write heads can be connected
- For RFID chips on the tool collar and in the pull stud
- Chip formats can be created to meet customer requirements
- Compatible for many systems:
Balluff, Pepperl+Fuchs, Siemens, Euchner (Mazak) and other systems are possible
- Tool data can be imported using various scanners
- Tool data can be imported and exported using various codes – barcode, data matrix code and QR-code



Laser pointer

Features

- Optics carrier including CCD camera and pneumatic quick adjustment mechanism
- Optional laser pointer for detection of the cutting edge
- Activation by pressing axis quick adjustment mechanism
- Laser corresponds to laser class 1

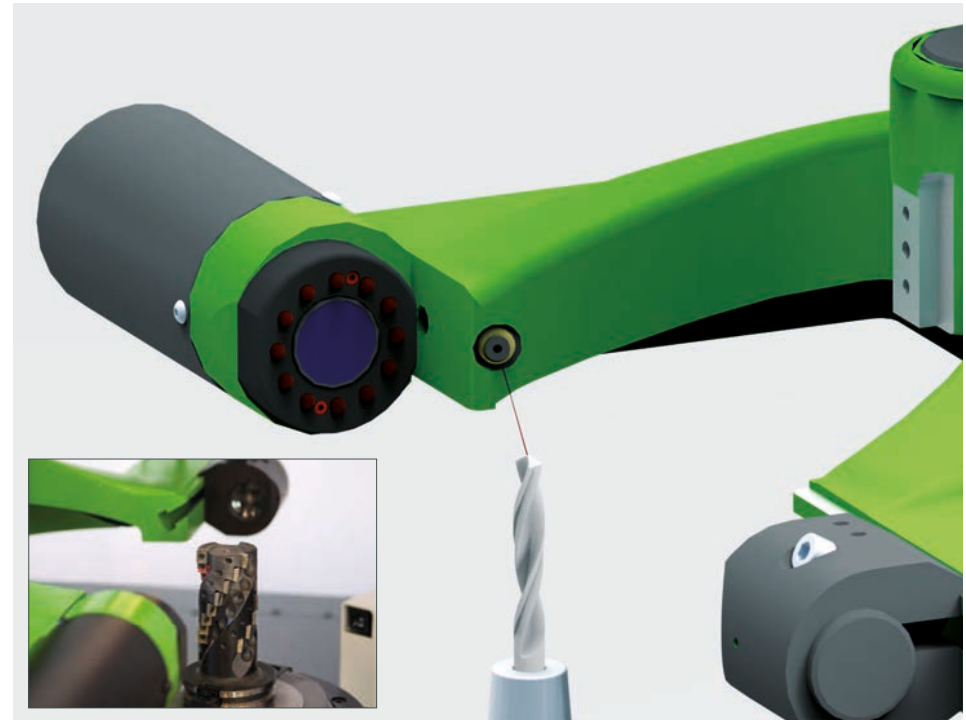

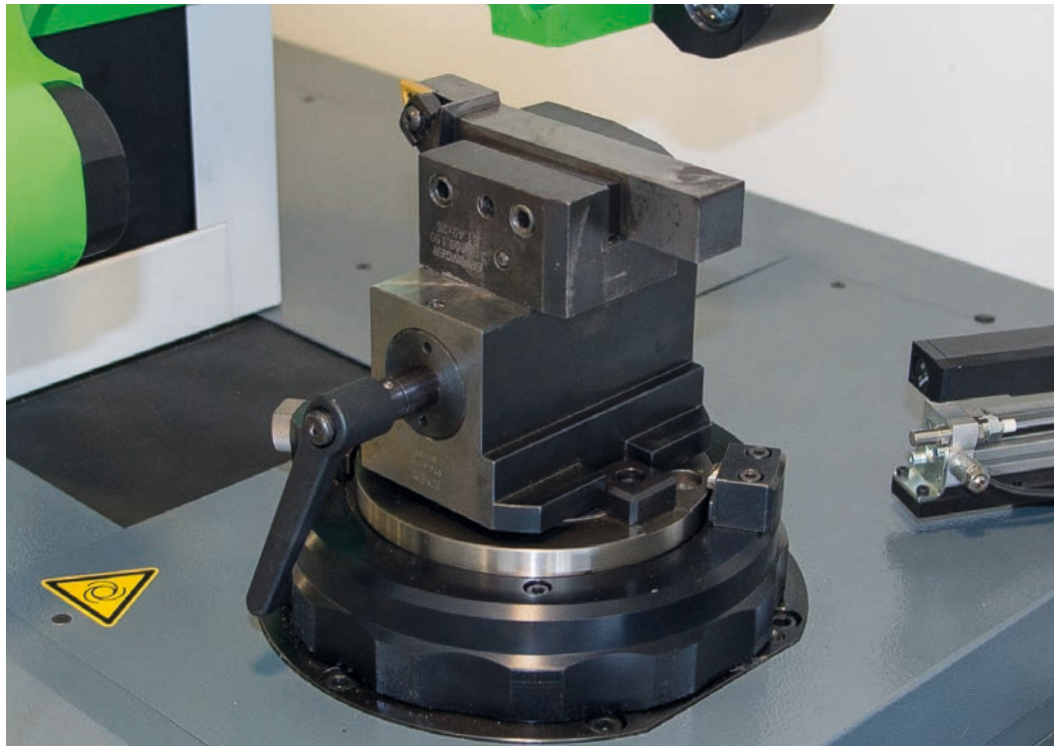
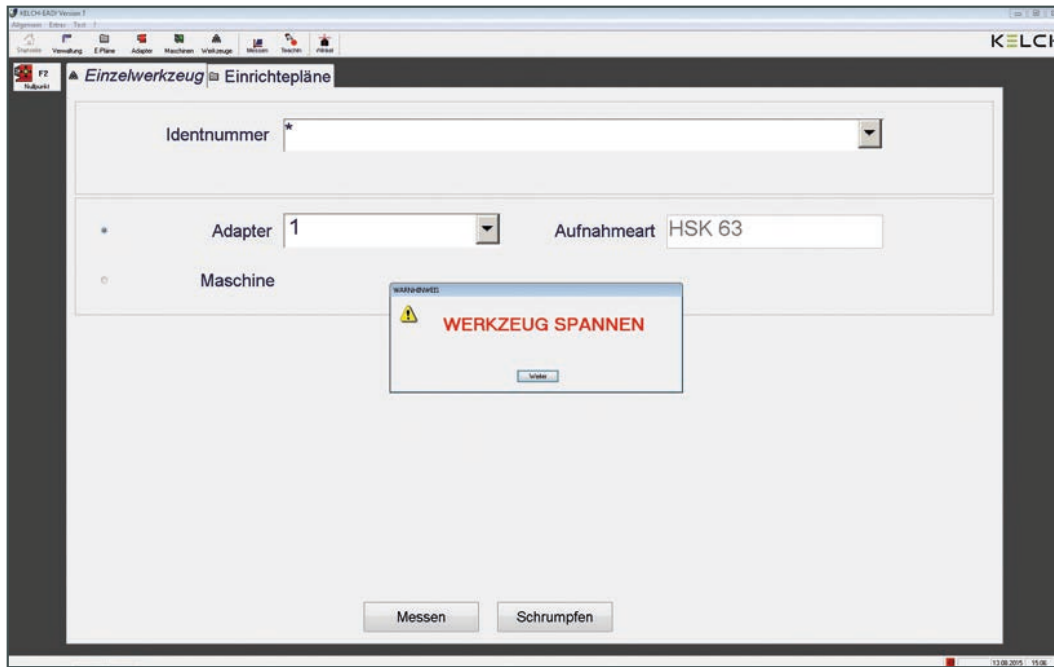

Rear clamping monitoring

Scenario

If you forget to clamp the tool in the spindle before measuring, an incorrect measured value will be recorded and possible damage caused to the workpiece or poor machining results produced.

Solution

The solution to this problem is rear clamping monitoring. This combination of hardware and software controls the pneumatic clamp on the spindle at all times. The EASY software only permits the measuring process to start once the tool has been properly clamped. This option is also indispensable for reliable setting within the process.

Release mechanism

for angle head tools

Features

- Release mechanisms for all common SK, PSC, HSK and VDI adapters
- Release mechanisms for driven and non-driven tools
- Customised solutions also possible

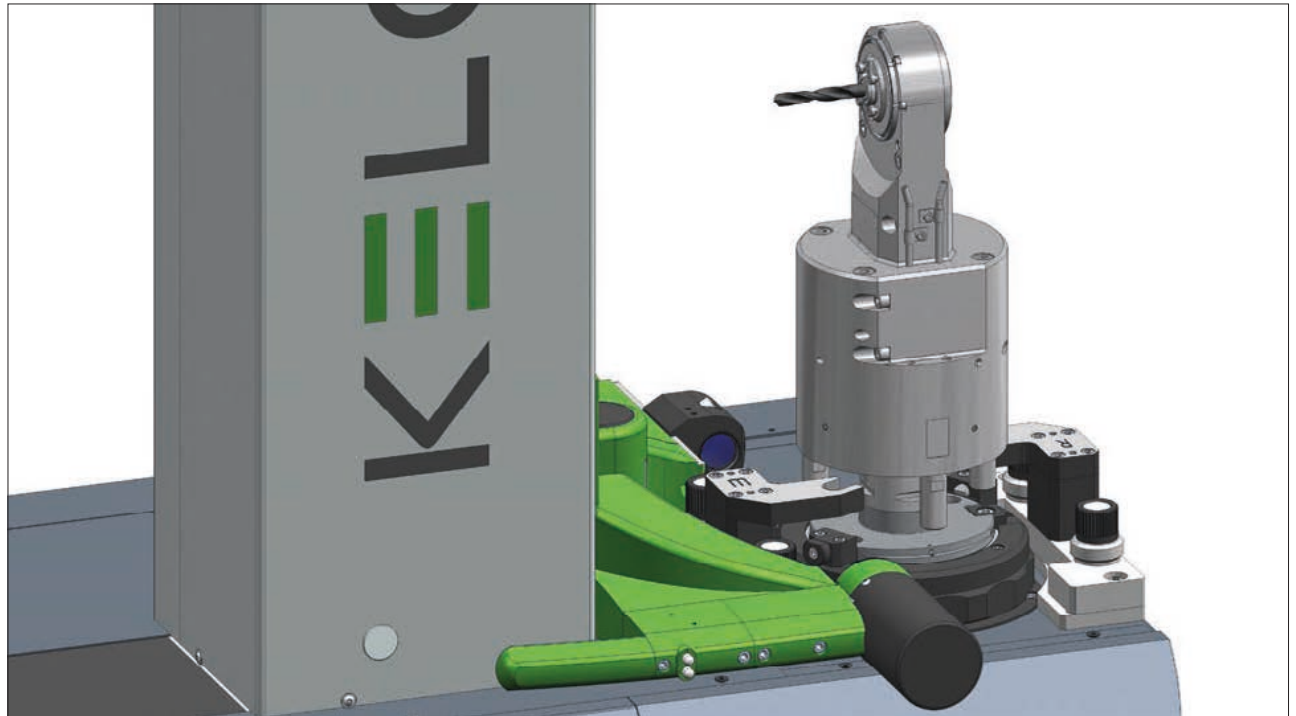

Length adjustment

Features

- Hardware and software for automatic adjustment of tools to their target length*
- Adjustment of hydraulic expansion chucks, collect chucks and Whistle Notch

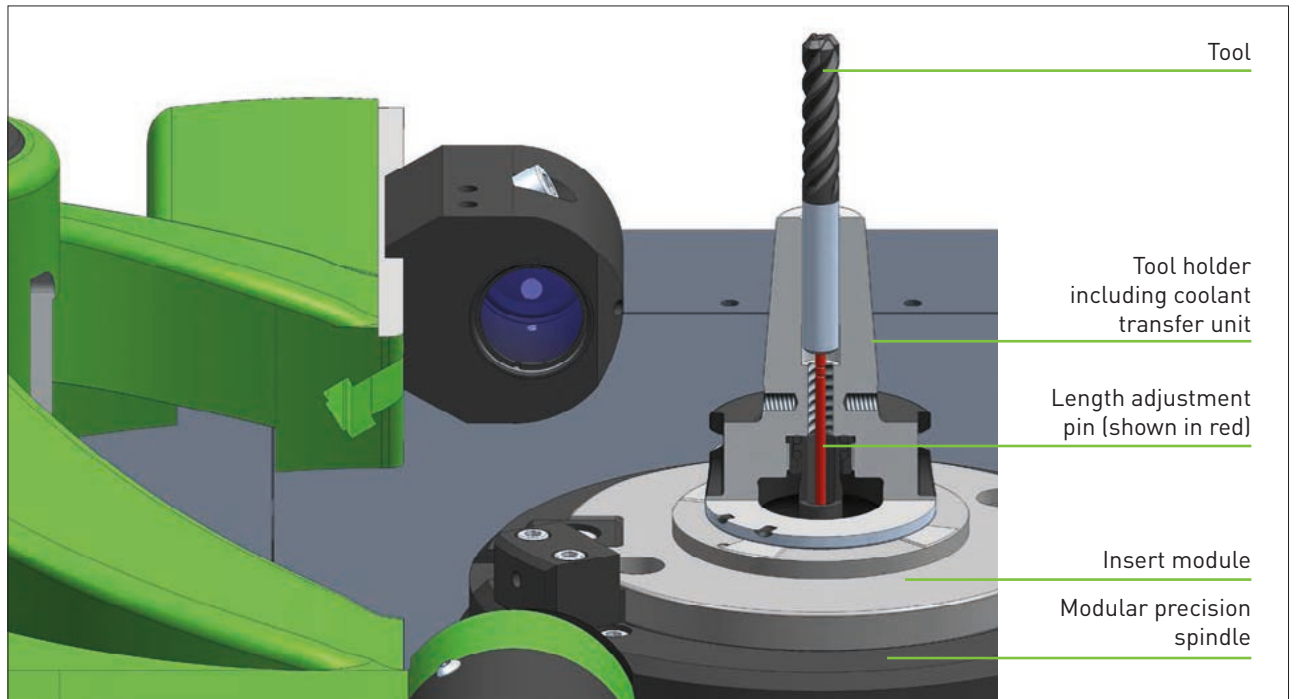

* Only for the KENOVA set line V9xx and V9xx-S ranges

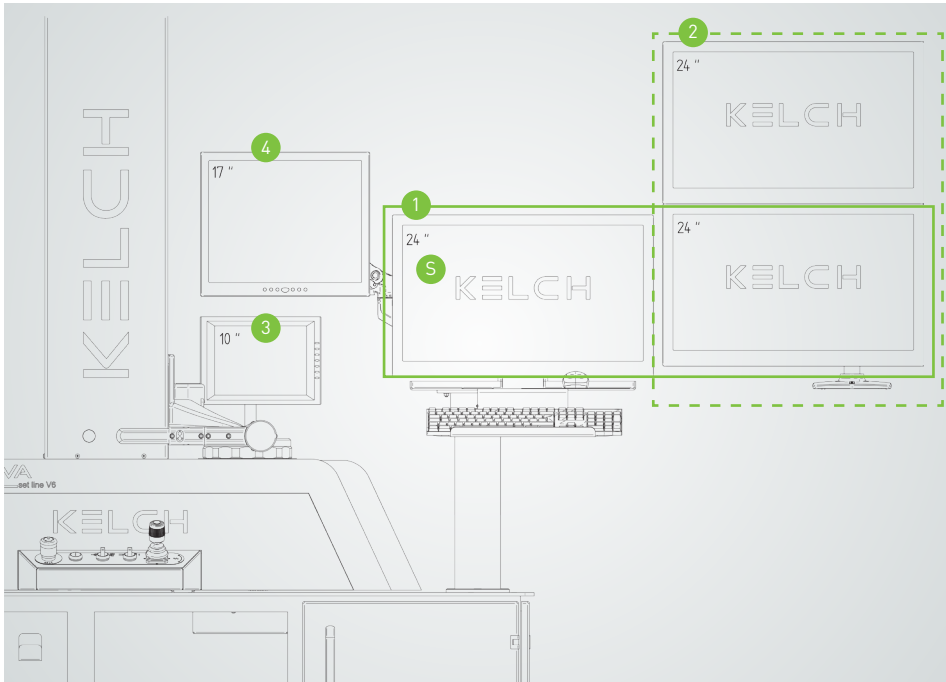

Monitor combinations

Versions

- S Standard version: 1 x 24" monitor
- 1 Combination of 2 x 24" monitors beside each other
- 2 Combination of 2 x 24" monitors above each other
- 3 Additional 10" tool monitor that travels with the camera
- 4 Additional 17" tool monitor fixed upstream of the spindle on the base.

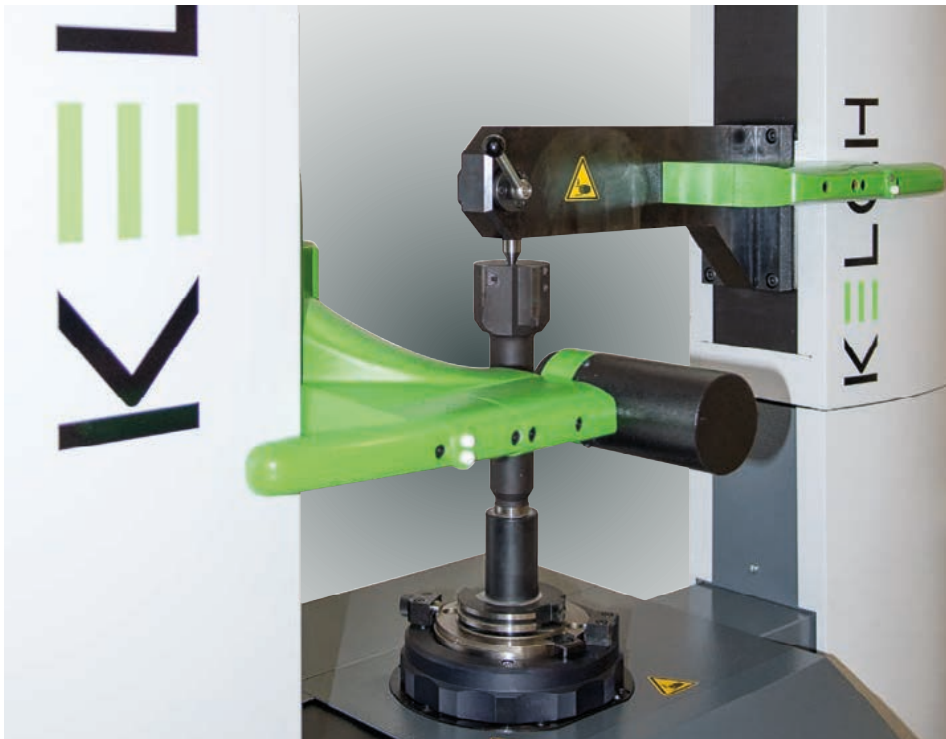

Tailstock

Features

- Additional tower parallel to the measuring tower
- For clamping long tools
- Up to 1200 mm
- Minimises wobbling of long tools, such as long reamers

Accessories for the PREMIUM line

Add to your tool presetter to meet your needs and requirements and customise it with our accessories.



Illustrated
example

Protective cover for V6 and V9xx / V9xx S units
· Protects from dust and dirt



Illustrated
example

A4 printer
· List printer for logging



Inserts for the modular precision spindle
· Insert modules which can be supplied for all common HSK, PSC, VDI, KM and SK tool holders



TUL mounting plates
· Basic element of the TUL system
· Available in different designs (for example refer to the TUL range for holding tools, inserts for modular precision spindles or other tools)
· Required space: L x W x H = 240 x 120 x 130 mm



Label printer
Thermo-label printer with or without dispenser

The simplest way to get a precise result

Fast, reliable and easy to use without the need of extensive training – these are the requirements that users place today on small control units in order to master the everyday measuring and presetting tasks.

The display and operator dialog are shown on a clearly designed touch screen. Logical measuring tasks, such as angle calculations, circle diameter and theoretical points can be activated easily by using your finger tip on self-explanatory module icons. The easy management of the adaptors, holders, tools and tooling sheets enables permanent access to the results in terms of the workflow.

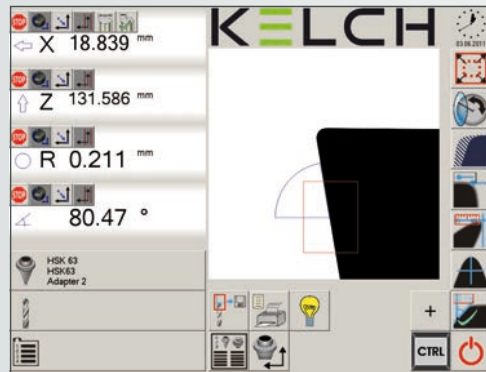

Measured image



Cutting edge inspection

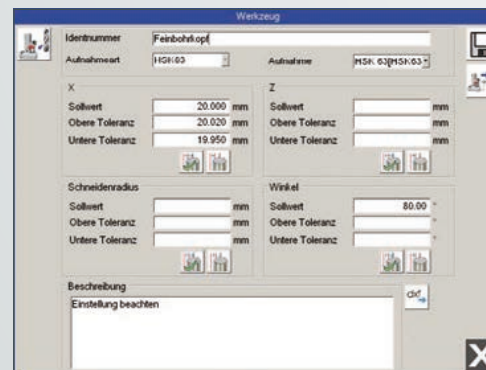

Tool data screen

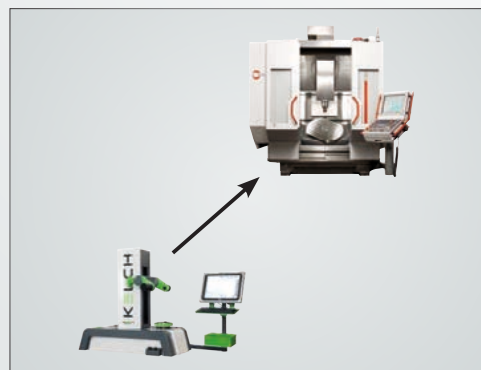

Data communication

KELCH CoVis

- Operated via a 15" touch screen
- Camera with a 5 x 5 mm measuring window
- Magnification of the camera image: 28 x
- Cutting-edge inspection with LED illumination and zoom function
- Total image function for fast measuring

- Database for adapter, zero point, tool and tooling sheets
- Additional measurements: radius / circle sections, cutting angles, general angles and centre of radius / circles sections
- Data output via printer or network

SOFTWARE
Intelligent
software
communicates
with machines



KELCH CoVis

The intelligent software – the heart of the INDUSTRIAL line for tool presetting and measurement.

- 1 **Measurement of dynamic cross-hairs:** For operator-independent and fast measurement of the maximum values of different geometries. The cross-hair automatically finds the cutting edge and remembers the maximum values once the total image has been activated until the measurement can be restarted, enabling the individual cutting edges of multiple cutting-edge tools to be compared.
- 2 **Measurement of fixed cross-hairs:** The fixed cross-hair acts like a projector, with the cutting edge having to be manually positioned on the cross-hair. Previously press the Focus key to adjust maximum focus.
- 3 **Measurement of radii:** Radii are measured automatically as soon as a suitable radius has been detected in the image. Measured on the basis of the best-fit process; free choice of ROI.
- 4 **Measurement of angles:** Angles are measured automatically as soon as the cutting edge has been detected in the image. There are several angle measuring options (supplementary angle, enclosed angle etc.)
- 5 **Theoretical points:** Theoretical geometries can equally be recorded and measured automatically and operator-managed. This can involve the theoretical point with counterbores, the theoretical length or the radius on the edge of the drill.
- 6 **Search beam:** The complementary value at the intersection of the search beam is measured with the contour of the tool by fixed specification of either the X or Z coordinates.
- 7 **Data management:** It includes an adapter menu for specification of any number of adapters and machine management system, tool management system and set-up plans. Complete set-up plans can be produced and transmitted to the machines by post-processors. The machine menu is used to define different controls.
- 8 **Cutting edge inspection:** Top light control using different lighting intensities for the visual inspection of tools.

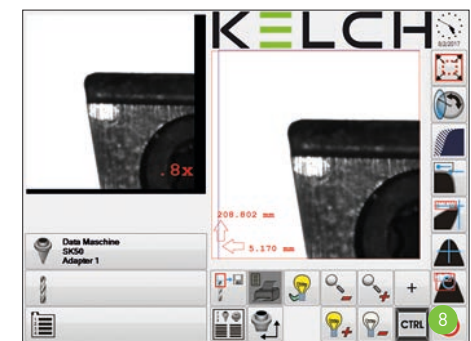
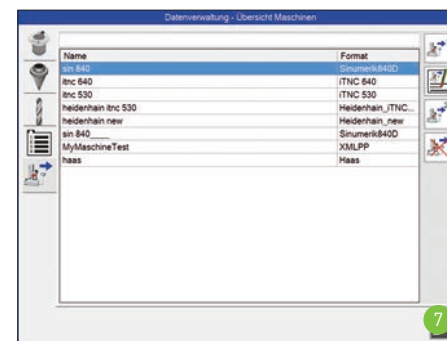
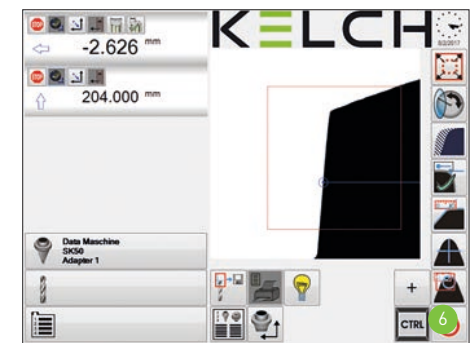
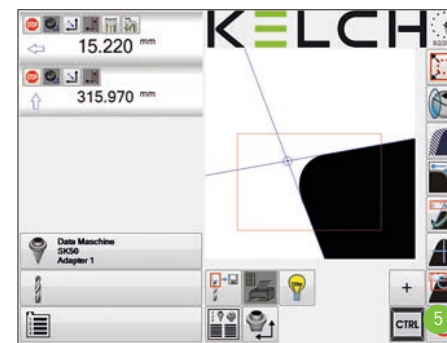
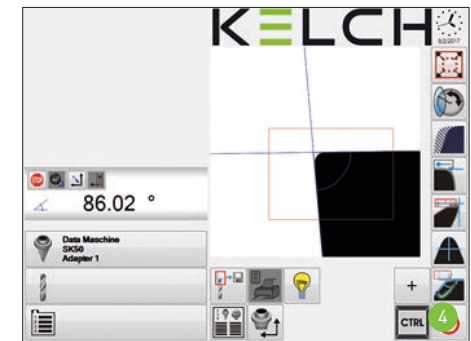
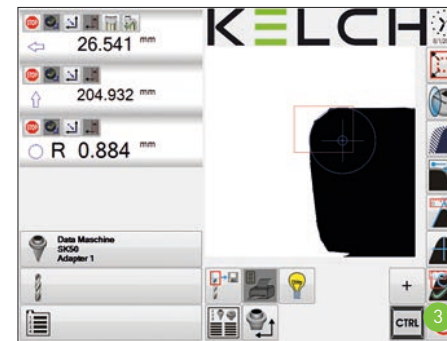
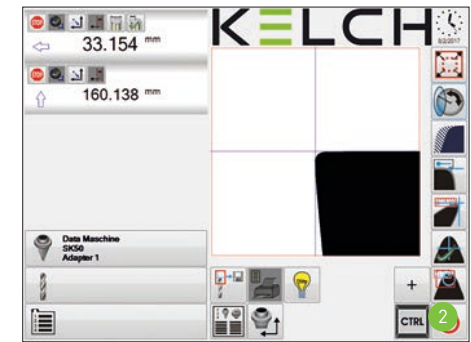
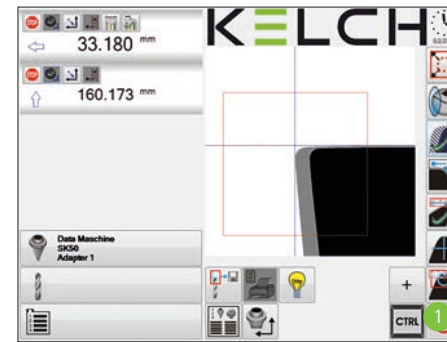

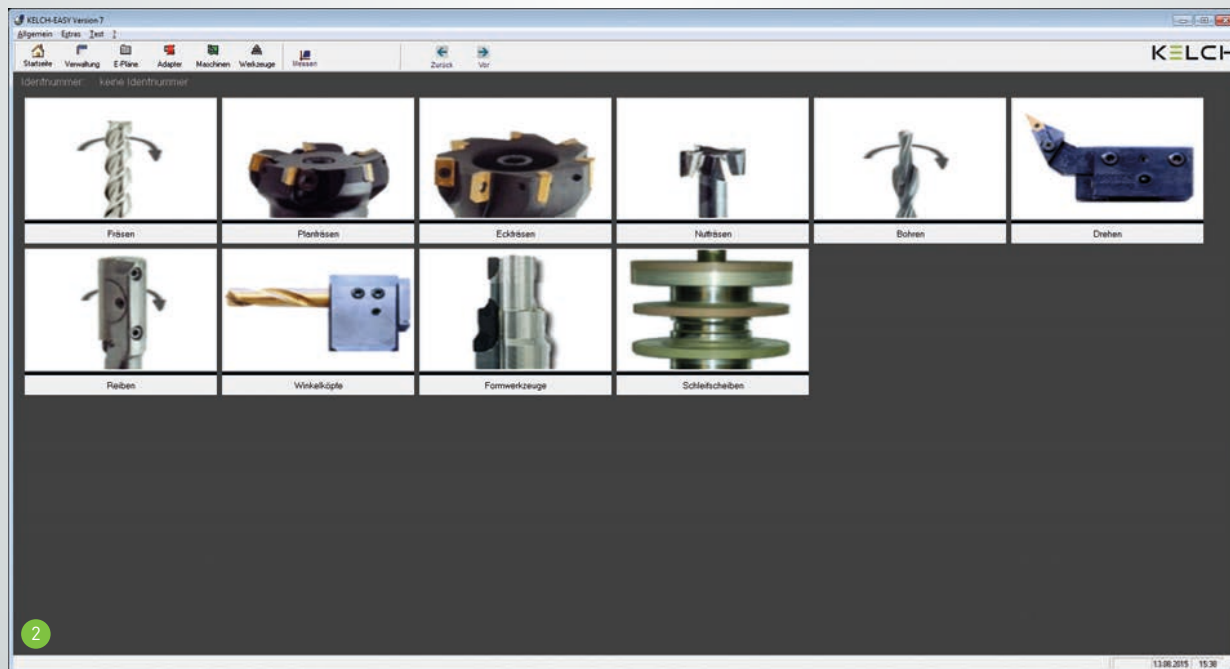
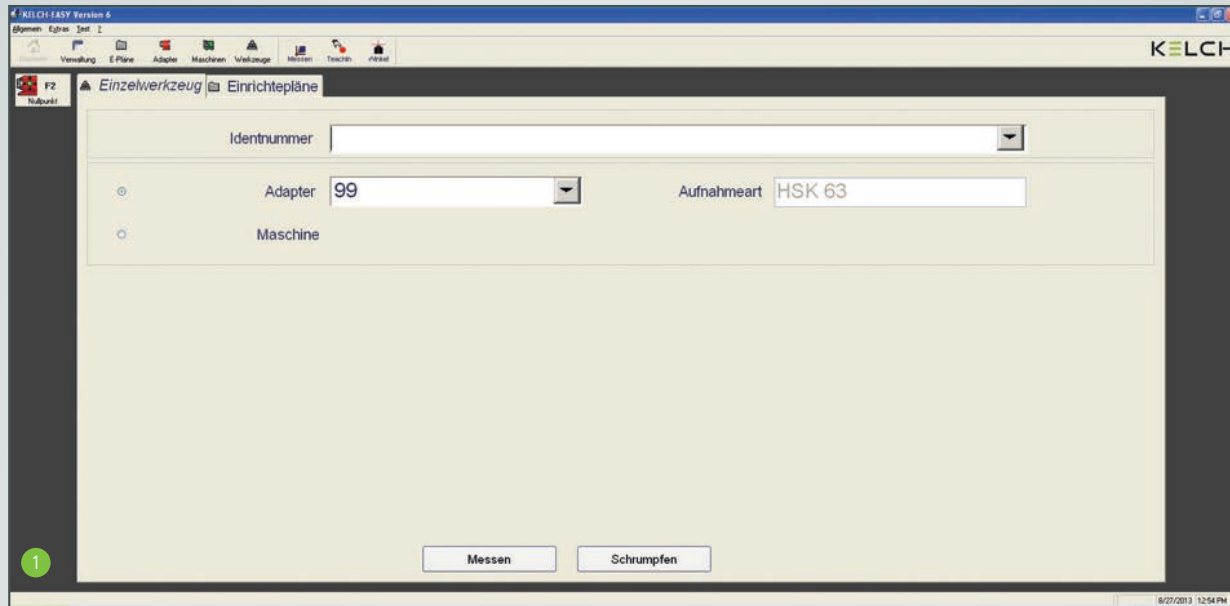

EASY

Fast measuring
made easy.

Measuring simply could not be easier with this software – and no special knowledge is needed. The clearly arranged user interface enables users to immediately navigate around the system using familiar forward/backward movements. A simple clear homepage is the direct entry to each measuring task. Other input screens, such as Picture Start, guide users step by step to the correct measuring result and also to the automatic measuring program. Adapters, machines, original tool forms, tooling plans and measuring processes are saved in the integrated database. The standard configuration includes bidirectional data communication (DNC) via a network card or serial interfaces in the KELCH data standard.

EASY

Measuring made easy.

Complex tools can be measured fully automatically for the first time with the Teach-in software option. Fully automatic measurement guarantees precise measuring results and enables tool presettlers to be operated regardless of the operator's knowledge and expertise. All measuring steps are retained and can be saved as a complete measuring program with the tool.

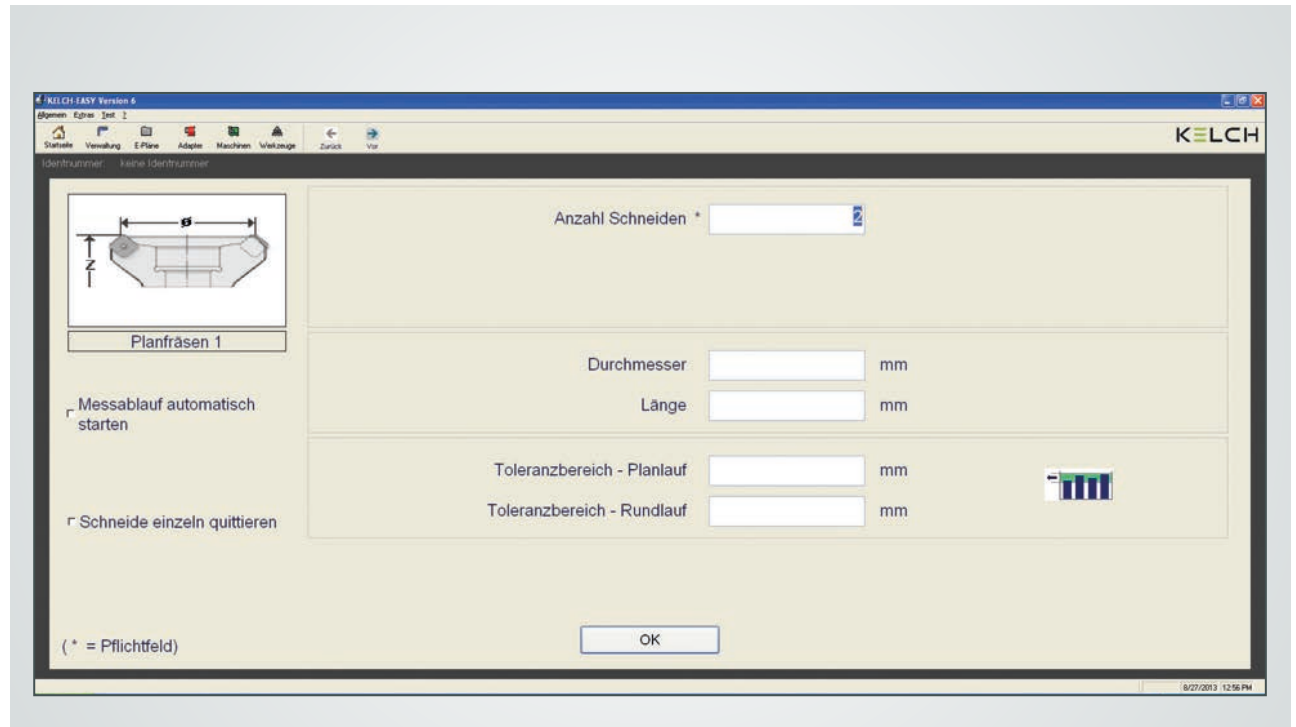

EASY leads each user reliably through the program with Picture Start using concise, easily understandable input dialogues. Practical pictures and graphics help with navigation and orientation.

Step 1: Input the measurement of individual tools or entire tooling sheets on the homepage. Then select the appropriate adapter on the tool presetter. If one of the tools entered has already been saved, the system calls it up by its identification number and immediately begins the measuring process.

Step 2: Select a tool using Picture Start. The selected tool then performs the measurement. Picture Start is KELCH's own in-house developed selection menu. Define the tool group you require using the different graphics. Simply click on the right graphic depending on the tool type and cutting geometry.

Step 3: Use ParaDirect (PaD) for inputting data. This is a concise, easy-to-understand input dialog into which you enter the target dimensions and tolerances. Only the mandatory fields need to be completed. This is sufficient for the measuring process. The corresponding measuring process begins when you have confirmed by pressing Enter. The data is entered from the PaD and the required measurement results are instantly available. Any actions required are clearly visible on the monitor.

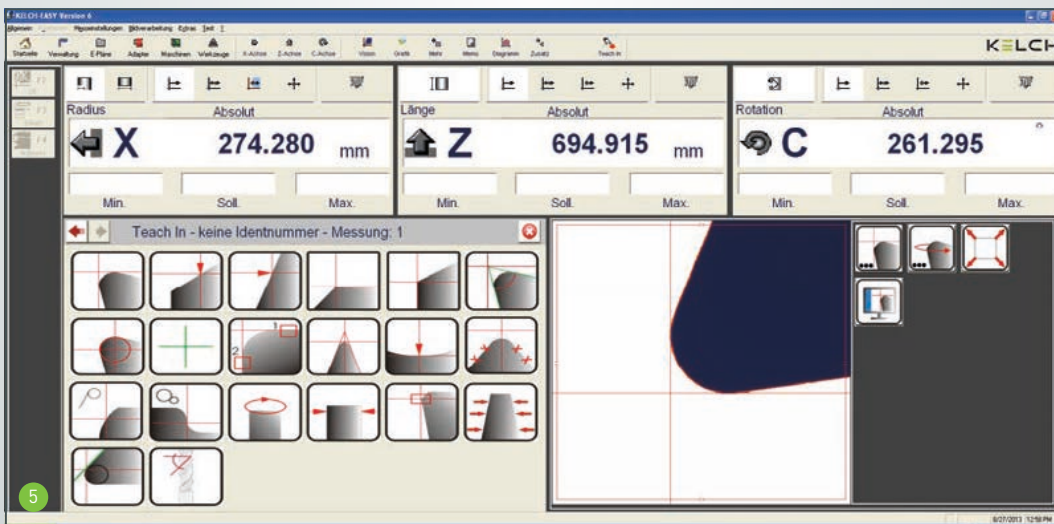
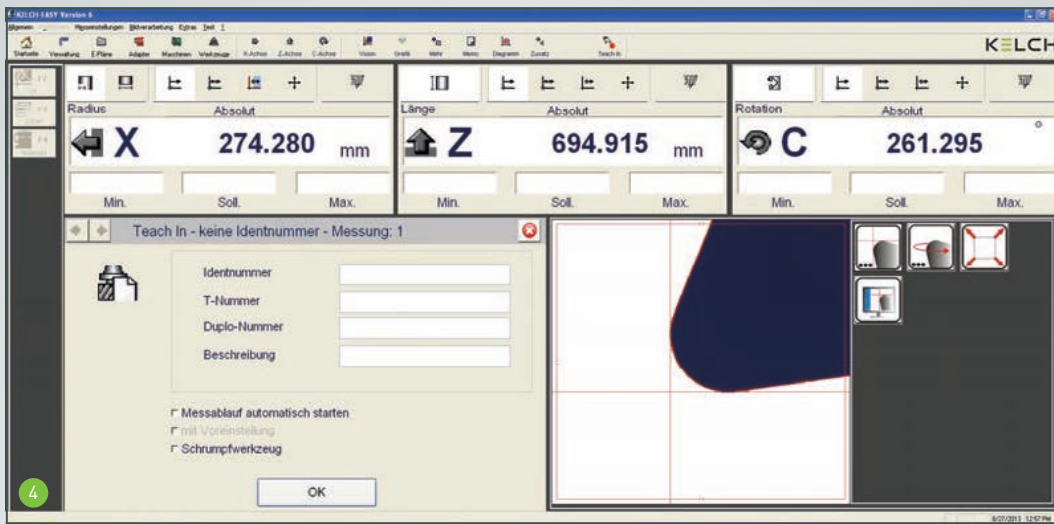

Step 4 + 5: The measuring process begins as soon as the identification number has been entered on the homepage (step 1). It starts automatically if a measuring run has already been entered.

It couldn't be EASIER.

The new user interface for the tool presetter's software delivers the most precise measuring results and is easy to use and understand. The familiar Home-Forward-Back navigation is similar to the method used in most browsers, meaning that you can return to the starting point by pressing just a single button. EASY software also comes with online Help, which is also easy to understand and structured in a similar way to Windows.

Performance features at a glance

Operator guidance	Simple input screens lead the user step-by-step to the right measuring result.
Automax®	Automatic, time-saving measurement of cutting edges without focusing.
Full-screen view	Tool cutting edge possible in full-screen view
Graphic logging	Graphic print output to log tools measured.
Online help	Integrated online help in Windows format.
Picture Start	Simple retrieval of automatic measuring processes via easy-to-understand tool images.
ParaDirect	Direct parameter input for the automatic measurement of new or unknown tools.
Contour measurement	Every form of cutting tool is simply scanned in.
Module recognition	Patented solution for maximum security.
Tool Tips	Context-sensitive help when starting up elements shows the user what activity is being called up.
Teach-in	Software option for individual setting and programming of measuring processes – easy, interactive and supported graphically.
Total image	Patented procedure to generate the envelope and measure the cut created.
DXF comparison	Target/actual contour alignment of tools by saving a template.
Reports	The relevant measuring results can be output in different protocol formats.
RFID	Tool identification by means of the RFID chip, which can be read and written.
Inspection	Tool inspection in the top light process to monitor the cutting process.
Tool management	Connection to external systems, such as TDM, Coscom, Fastems etc.
3D module	Creation of precise 3D models of the rotational and symmetrical tool.

KELCH EASY – Angle heads

Features

- Simple and fast measuring of angle head tools
- Variable angle setting from -90° to $+90^\circ$
- Diverse customised solutions can be achieved

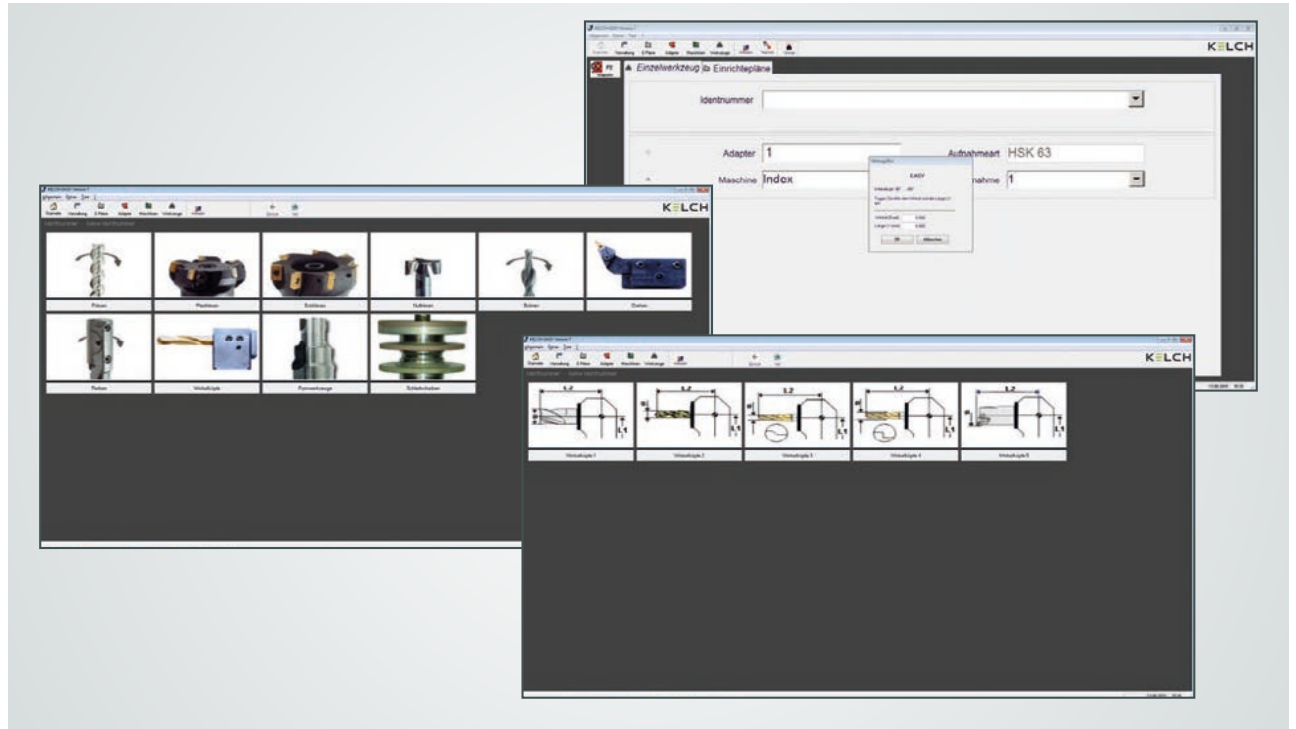

3D wizard

A fully functional 3D model in three steps

The 3D wizard lets you create a 3D model of the entire tool in a few steps, allowing you to use it for collision observation. EASY software records a point scan of a rotationally symmetrical tool with a contour scan, generates a 2D model, which can still be processed to close the contour gaps, and then extrapolates it into a 3D model. Issuing the file in .igs, .stp and .stl format enables the model to be used by the majority of simulation tools.

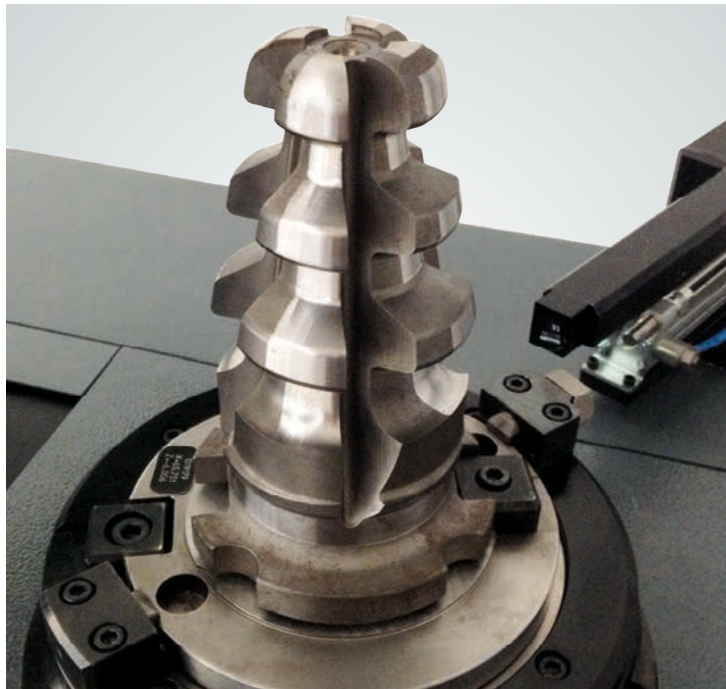

The Contour Software package offers the following:

Technology

- Simple contour comparison using DXF files
- Measurement of any geometric elements to the quality of surface and shape
- Straight and circular shapes can be formed from segments
- Extensive analysis is also possible using auxiliary elements
- Measurement of straight-grooved or spiral-toothed forming tools
- Contour scanning with 3-axis CNC equipment
- Synchronised switching
- Intuitive graphic interface
- Measurement of any distances, angles and radii
- Comparison with the target contour
- Tolerance observations
- Clear logging

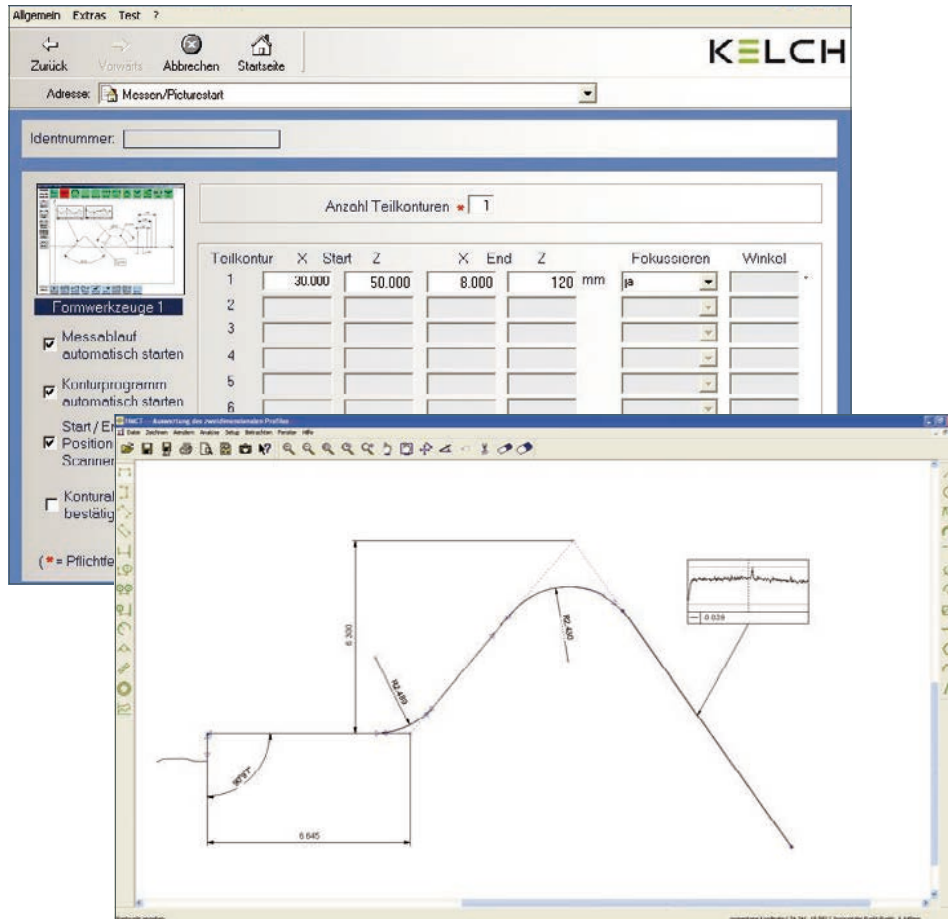

Contour Software

The intelligent solution.

KELCH Contour Software is ideal for automatically checking tool contours for straight or spiral grooved forming tools. After defining the start and end points, the contour is scanned in one or more partial contours. The recorded point coordinates are interpreted in an analysis programme and converted into a polygon. All geometrical elements can be extracted and dimensioned from the calculated, graphically displayed contour and also compared with the target contour. The geometrical comparison can be undertaken using specific data, such as target radius, angle or distance, or deviating from a predetermined optimum contour which is imported in DXF format, for example. Irregularities in individual elements can be displayed particularly clearly. The measurements determined and learnt in this way are saved as a reference file and are then available for the next measurement. The complete process therefore runs automatically from scanning to logging.

KELCH software interfaces

Everything at a glance!

KELCH measuring software ensures that you can always save tool-based data and transmit it to the right place. It does not matter whether the data comes from machine controls, tool management programs, CAD/CAM systems or other manufacturing systems. Now you always have the same consistent data throughout the entire system – missing data is now a thing of the past. Even simple errors, for example caused by transposed digits, are avoided, increasing process reliability and also efficiency in your company.

Regardless of whether you opt to use CoVis or EASY, KELCH helps you to conveniently transmit tool-based data by data transfer to the right place.



Engineering Services

The definition

Within modern tool management, KELCH Engineering Services looks after situation analysis, planning and project management, system integration and process implementation, as well as the digitalisation of all processing work in production. This involves defining a technically and economically optimum process chain, as well as optimising NC programs and tool plans within work scheduling.

The aim

The aim of the Engineering process is to identify the actual cost drivers in the process. Significant savings can generally be achieved by optimising existing tools. Specially developed multilingual software tools support this systematic approach, enabling a comparative analysis of different situations. The results reveal hidden potential for economies, which the majority of customers can then often translate into real money.

SERVICE

Smart Factory Services

Industry 4.0
technology transfer
in practice





Situation Analysis

Situation Analysis

- Determine the customer's current situation: number of machines, tools and workpieces, and record the manufacturing structure
- Highlight potential areas for improvement: value stream mapping, lean manufacturing



Planning & Project Management

Planning & Project Management

- Define and/or optimise the production layout
- Optimise machine equipment: initial equipment packages/retrofitting packages, integrated optical measuring systems
- Tool Room Concept: layout and equipment
- Tool Logistics Concept



System Integration & Process Implementation

System Integration and Process Implementation

- Networking and interfaces: machines/tool presetters/measuring systems, CAD/CAM, MES, ERP, tool management, tool issuing systems, PLM
- Commissioning and production go-live
- Integration of optical measuring systems



Digitalisation

Digitalisation

- Data processing and recording: cataloguing components / processing existing data logs
- Creation of a database: DIN 4000/ISO 13399-compliant tools, test and measuring equipment, machines, storage locations/ systems, workpieces (products), NC programs



Procurement & Storage

Procurement and Storage

- Local purchasing: system providers/procurement service providers
- Storage: consignment store, storage in issuing cabinets at the customer's premises, monthly billing
- Logistics: prompt provision where needed

Tool Services

The definition

KELCH Tool Services deals with the everyday cost pressures on manufacturing companies. KELCH directs companies along a more efficient and effective route to becoming more streamlined and successful, focussing on their core competences. There is also indirect potential for cost savings, above all with main regional suppliers.

The aim

The right tool at the right place at the right time! We look after every last detail – from procurement and storage to tool assembly and management.

Financial Services

Leasing Partner

Our leasing partner is an expert in financial solutions geared to small to mid-sized businesses and enables us to offer our customers the freedom and flexibility they need to conduct their businesses: with one-to-one advice and demand-led financing. For your KELCH Smart Factory Services.

Operate Leasing / Finance Leasing

The lessee purchases the temporary right to use a capital asset that can generally be cancelled at any time. The lease contract is essentially the equivalent of a civil lease contract. Unlike medium- and long-term financing, Operate Leasing focuses on the short-term use of the capital asset, enabling customers to overcome bottlenecks in production or in sales.

A key feature of Operate Leasing contracts is that the lessor's financing costs are not generally amortised within the term of the contract. Full amortisation can only be achieved by the lessor leasing the asset several times and ultimately selling it.

Features of Operate Leasing:

- Contract period:
relatively short contract periods. When a contract is concluded for an indefinite period, there is a right to cancel within the agreed periods. The service life of the asset exceeds the service life specified in the contract.
- Economic risk/Asset risk:
borne by the lessor. In this context, economic risk/asset risk is understood as meaning the risk of technical obsolescence of the leased asset, theft, technical faults or damage.
- Maintenance:
is the responsibility of the lessor. As the leased assets are often leased to several lessees in turn, it is in the interest of the lessor to maintain the asset in good condition.

Features of finance leasing:

- Contract period:
long contract terms with basic lease periods that cannot be cancelled. The basic lease period is approximately the operational service life of the leased asset.
- Asset risk:
is borne by the lessee. This also includes payment for incidental repairs and the arrangement of insurance.
- Maintenance:
As the lessee has generally initiated the procurement and/or production of the leased capital equipment, he is also responsible for taking measures to retain its value.



Tool Assembly & Management

Tool Assembly & Management

- Provision of tool systems as a service: assembly, adjustment and measurement, recycling, dismantling and disposal



Optimisation & Data Administration

Optimisation and Data Administration

- Preparation of existing data sets
- Optimisation of tool data: in tool management systems, tool issuing systems, reducing the range, stock and costs, among other things
- Adaptation of technological data: optimising NC programs, use of state-of-the-art technologies at all times



Technical Support & Servicing

Technical Support & Servicing

- Maintenance contracts, repair service, hire and rental equipment, extended warranties, data recovery, software support, 24-hour services, retrofitting, calibration and certification, remote maintenance, responsibility for total maintenance



Leasing of Capital Equipment

Leasing of Capital Equipment

- Avoidance of high initial expenditure
- Use of attractive financing models
- Pre-emptive right to purchase at the end of the flexible leasing model



Flexible Accounting Models

Flexible Accounting Models

- Billing on a time and labour basis: e.g. with short-term services
- Monthly billing: precisely based on goods consumed

KELCH goes IoT

KELCH IoT improves efficiency and minimises failures.

Optimum service with perfect support and fast response, thanks to TeamViewer remote maintenance software. This pre-installed software can access the unit directly, even if it is not integrated in the customer's network. Fast support is therefore guaranteed without lengthy travel times.

As a customer, you can now concentrate on your work with the new KELCH "TeamViewer IoT"* IOT solution. KELCH monitors the status and full performance of the tool presettlers, helping to achieve almost 100% availability.

By control of the tool presettlers' performance data, including temperature, light intensity, vibrations, computer's CPU load etc., it is possible to preventively avoid a malfunction.

For instance, too strong light intensity could have a negative impact on the measurement. KELCH Service detects limit values and alarms and proactively contacts the customer. This predictive and preventative maintenance approach enables unplanned failures to be reduced to a minimum.

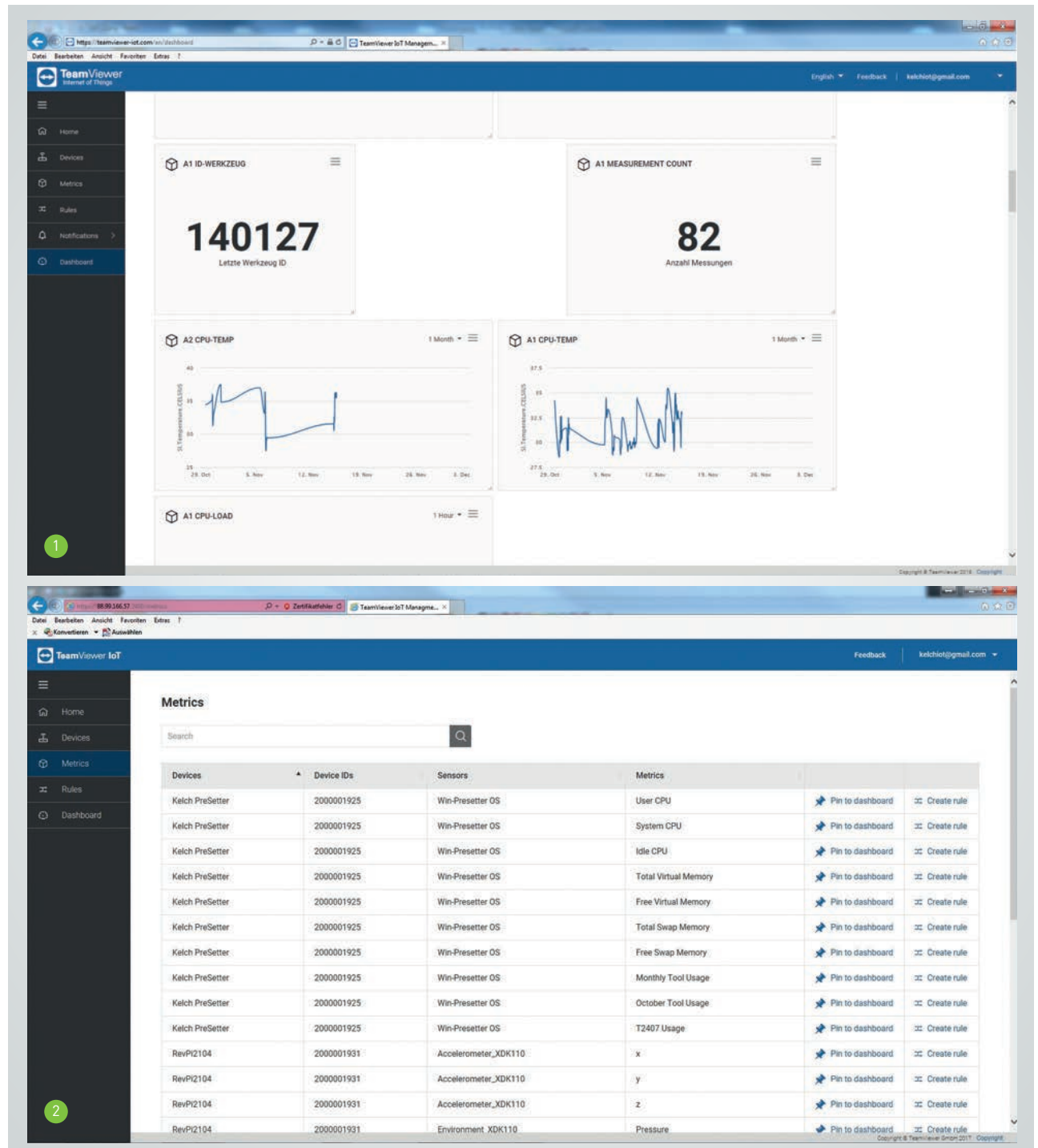

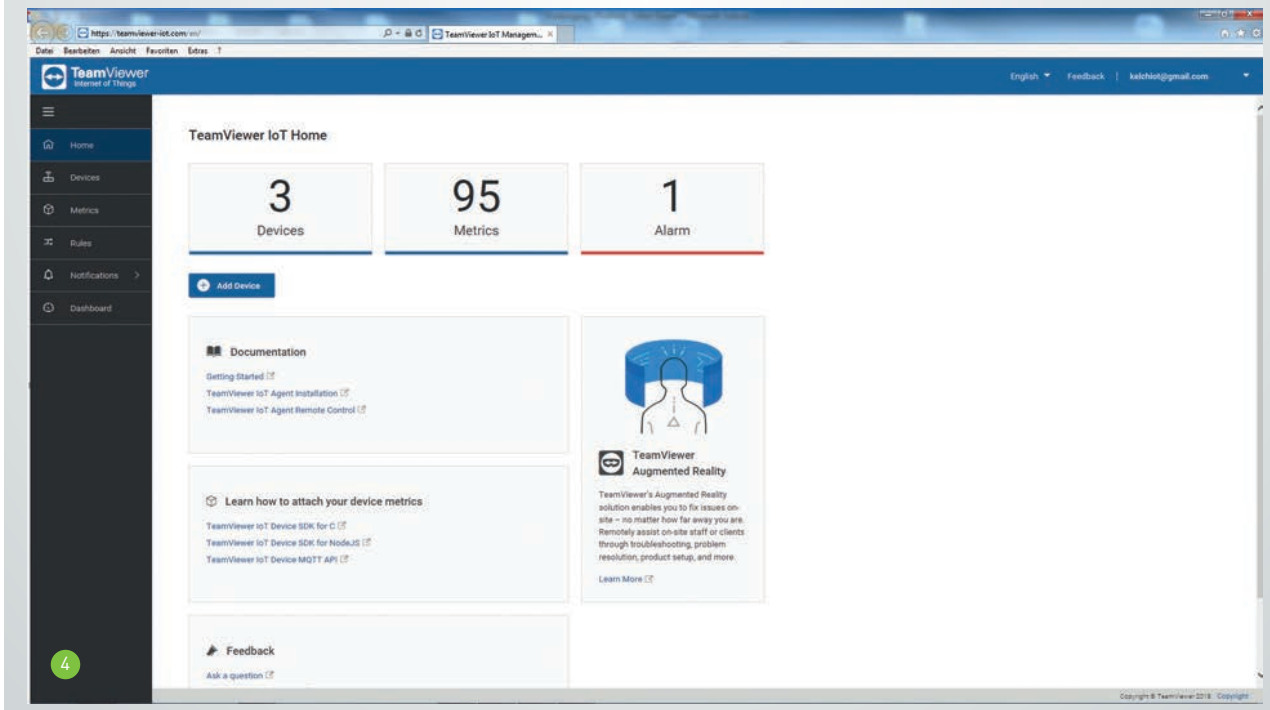
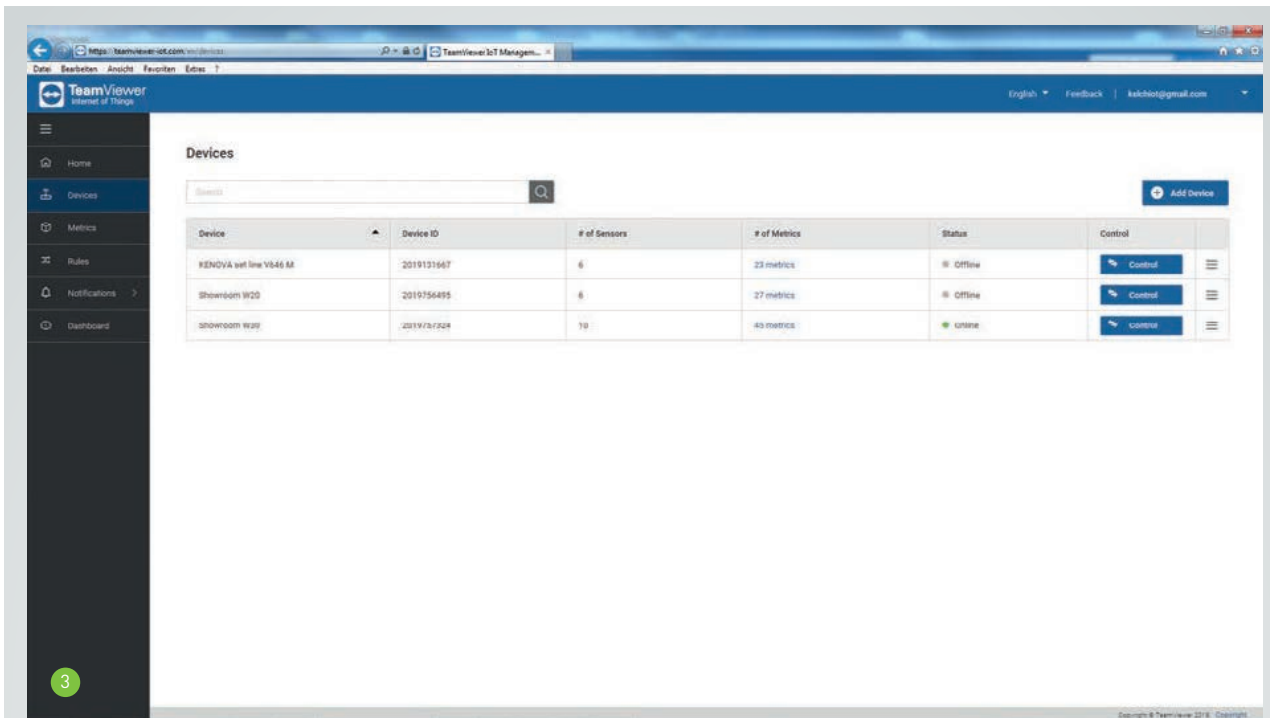

Remote control of your equipment

And many other options.

KELCH's "TeamViewer IoT"* IoT solution allows online support, training, software updates and optimisations to be performed simply and conveniently remotely. Fast, flexible and customer-focused.

- 1 Control of the status and various parameters.
- 2 Diverse display options for different parameters.
- 3 Fast and clear presentation of the connected equipment.
- 4 Overview of the dashboard.

* More information at: www.teamviewer.com/en/products/iot/

KELCH Service

Good service starts before the sale.
 KELCH provides service before, during and after the sale – without any ifs and buts.

KELCH is well-known in the industry for its excellent advice and its service is in no way inferior to this. We offer you an “All-inclusive full-service package”: you’re always well looked after, from purchase to support and maintenance.

We understand how important good service is!

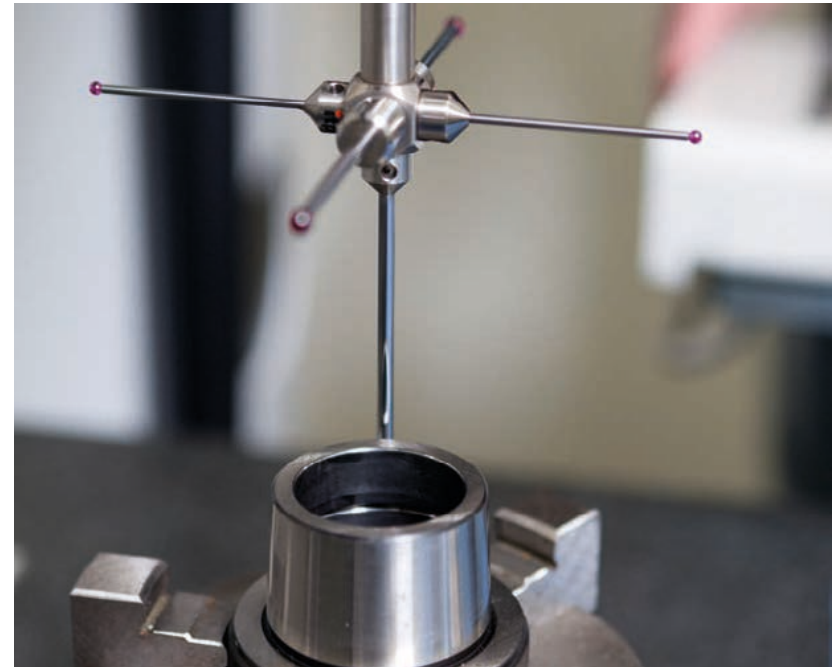

	Basics	Individual maintenance	Maintenance contract Standard	Calibration contract Precision tools
Spare parts service	✓			
Spare parts service at preferential prices		✓	✓	
Repair service	✓	✓	✓	✓
Lease and rental devices	✓	✓	✓	
Extended warranty for new equipment			✓	
Data recovery (if possible)			✓	
Software support		✓	✓	
24-hour service		✓	✓	
Retrofit, update, upgrade	✓	✓	✓	
Retrofit, update, upgrade at preferential prices			✓	
Calibration / certification of force sensing bars, measuring gauges and test arbors	✓			
Calibration / certification of force sensing bars, measuring gauges and test arbors at preferential prices				✓

The KELCH seal guarantees greater reliability with all KELCH equipment. This seal assures you at all times that you are receiving the best, most professional service for all your KELCH equipment. We guarantee absolute quality and offer maintenance contracts combined with interesting bonus programs and discounts. Benefit from KELCH service and only put your trust in the original.

Basics

We keep all common spare parts from the latest series in stock at fairly calculated prices exclusively for our customers and authorised representatives. In most cases we are able to quickly deliver spare parts or offer suitable alternatives even for systems up to 15 years old.

Maintenance contract

One-off cost for the maintenance of an initial system including travel costs.

Repair service

We offer you the option of having your units or components (e.g. your PC) repaired quickly in-house by KELCH. You save on travel costs or dual journeys, if the fault cannot be resolved at the first attempt. We can also organise collection and also return delivery.

Lease and rental devices

We would be pleased to supply you from our pool of lease and rental units (if available) for the duration of the repair of your components at KELCH. Our maintenance contract customers have privileged access to this service and, of course, at special rates.

Extended warranty

If you conclude a maintenance contract and if the first service is carried out within twelve months after the purchase of a new unit, then the warranty is automatically extended to 24 months.

Data recovery

It can happen quickly. Following a power failure or other unforeseeable events, the database has become unstable and the last backup is already too old to restore – important data is lost. We offer our maintenance contract customers a data recovery option at KELCH. Invoicing is on a cost-basis.

Software support

We offer our maintenance contract customers priority support for software issues. Support is invoiced for every half-hour started.

24-hour service

We offer our maintenance contract customers a guaranteed response time of 24 hours (Monday to Friday from 8:00 to 17:00, except on public holidays).

Retrofit upgrade

Only we offer you the opportunity to update your unit to the state-of-the-art. It is crucial to stay up to date especially with fast-moving control technology. The progressive discount rate based on spare parts service and the benefits of a maintenance contract naturally also apply here.

Calibration and certification of KELCH measuring equipment

We calibrate and certify your KELCH measuring equipment in-house, such as measuring gauges, test arbors and force sensing bars. Optional: If you do not wish to deal with this yourself, we can take responsibility for it with a calibration contract.



TECHNICAL DATA

INDUSTRIAL line

KENOVA set line V3xx

Technical data

EQUIPMENT DIMENSIONS without base

Length	1267 mm
Width	570 mm
Height	1273 mm
Weight	300 kg

MEASURING RANGE

Longitudinal axis X (Ø)	-100 to 400 mm
optional X (Ø)	-100 to 600 mm
Transverse axis Z	600 mm

Front view

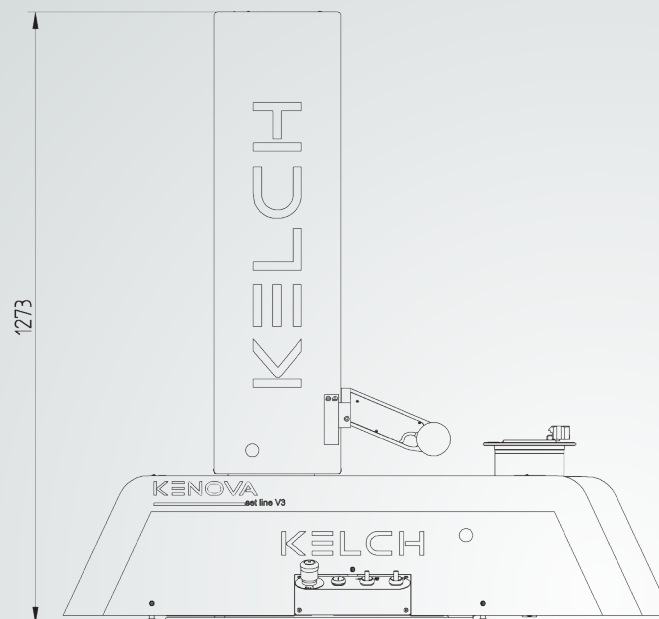

Side view

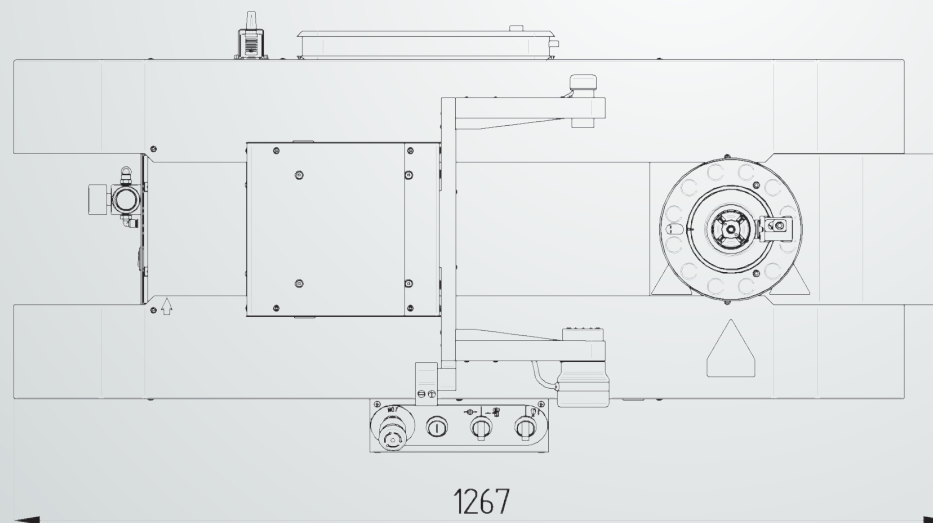
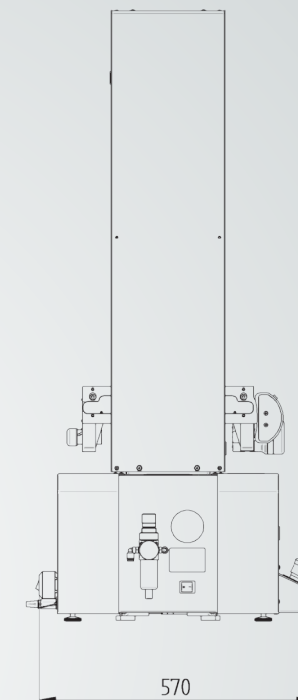

Top view

Front view

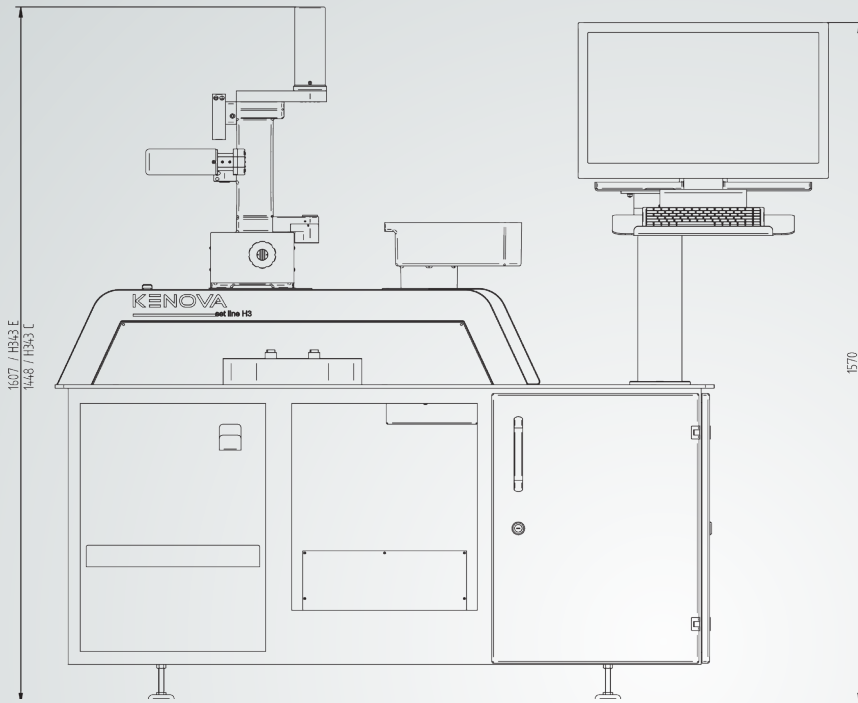

Side view

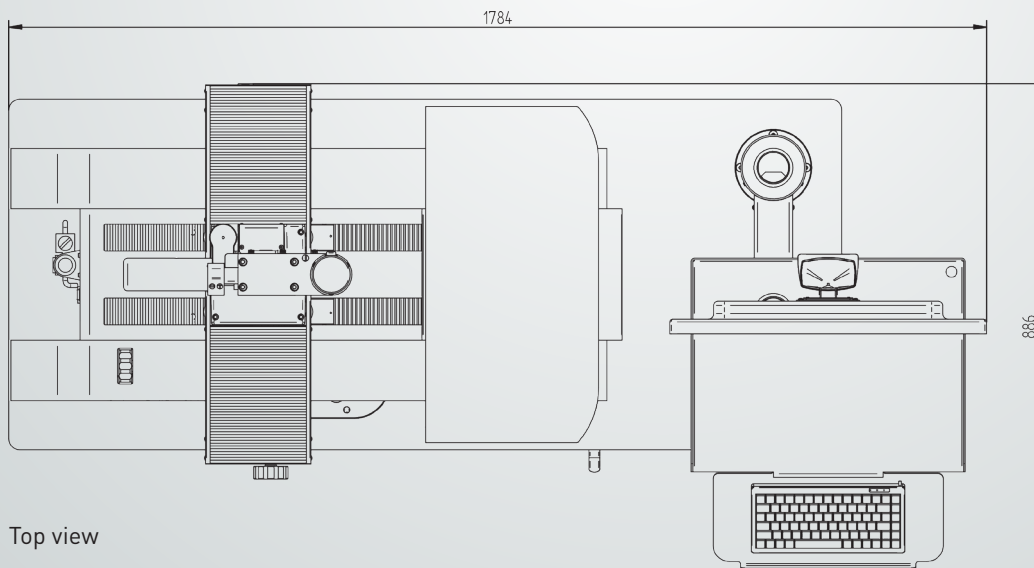
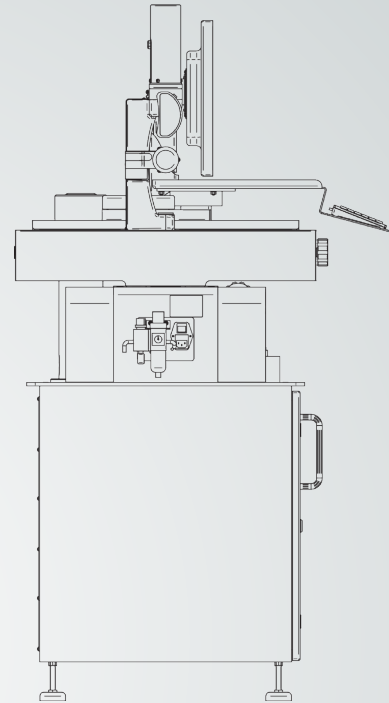

Top view

KENOVA set line H343

Technical data

EQUIPMENT DIMENSIONS with TUL rack V

Length	1784 mm
Width	886 mm
Height	1570 mm
Weight with CoVis / EASY	460 / 475 kg

MEASURING RANGE

Longitudinal axis X (Ø)	400 mm
Transverse axis Z	300 mm

TECHNICAL DATA

PREMIUM line

KENOVA set line V6xx

Technical data

EQUIPMENT DIMENSIONS with TUL rack V

Length	1784 mm
Width	1158 mm
Height	1995 / 2195 / 2395 mm
Weight	475 / 505 / 535 kg

MEASURING RANGE

Longitudinal axis X (Ø)	-100 to 430 mm
Optional X (Ø)	-220 to 310 mm
Transverse axis Z	600 / 800 / 1000 mm

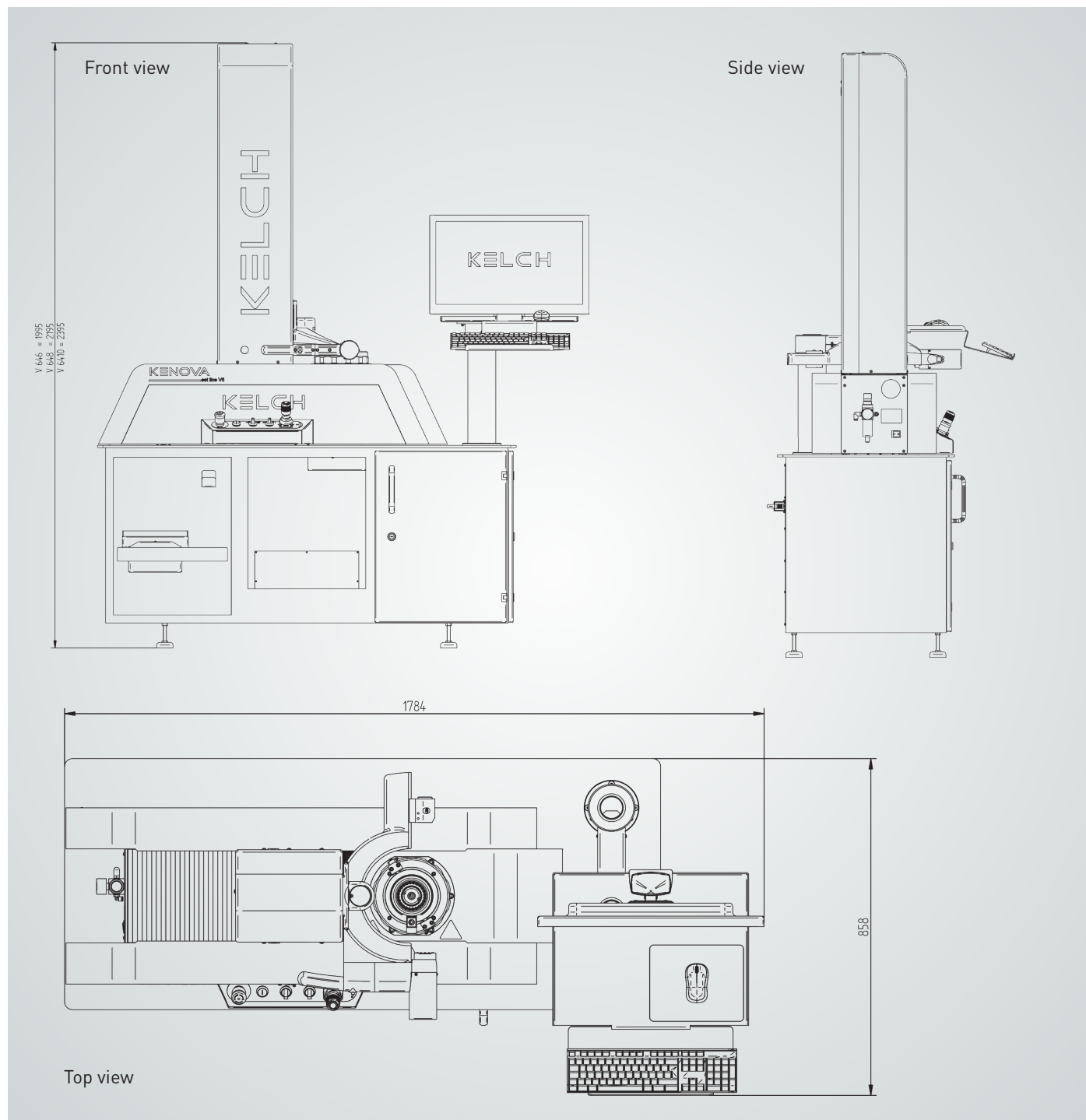

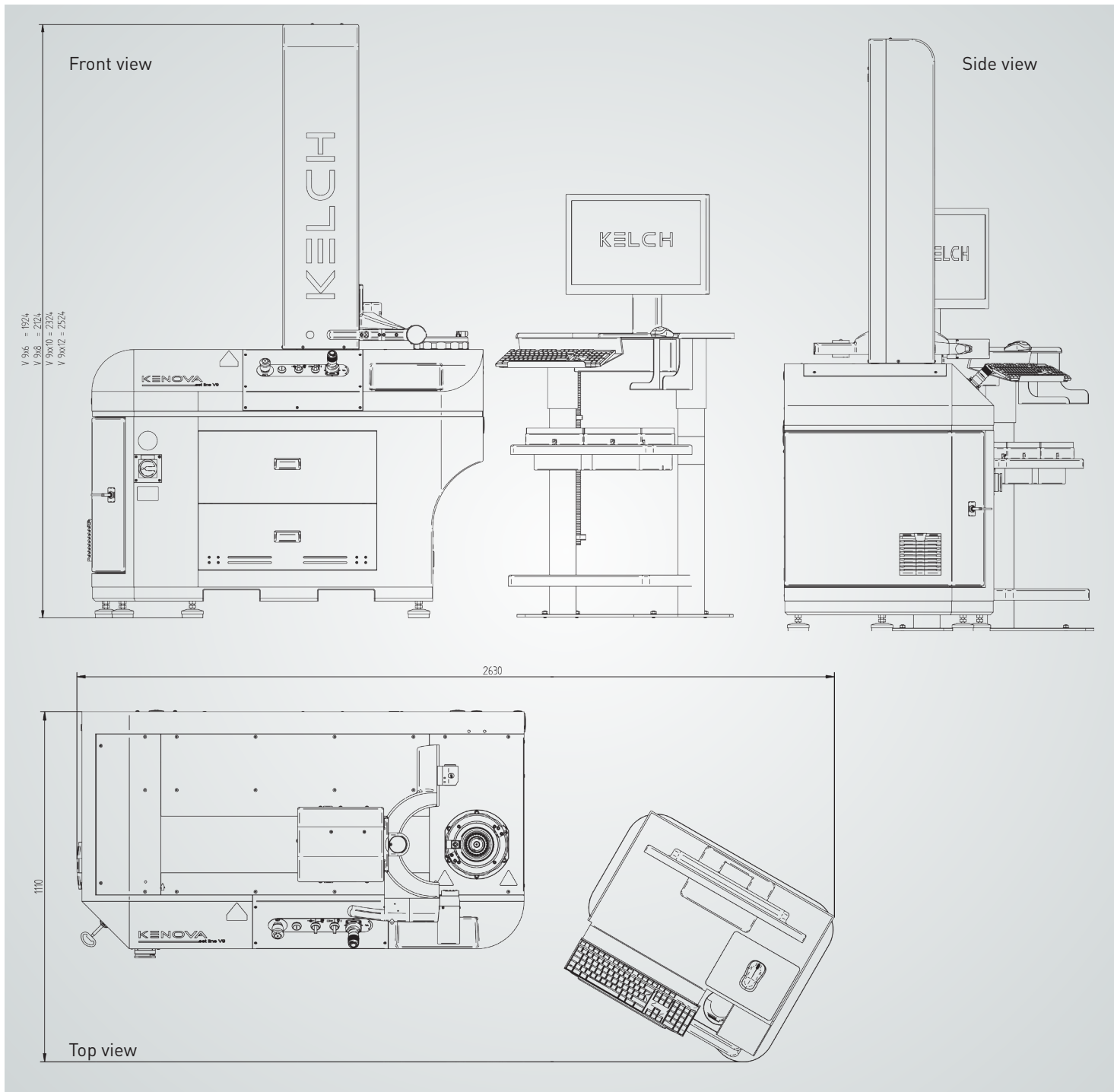

KENOVA set line V9xx

Technical data

EQUIPMENT DIMENSIONS with TUL rack V

Length	2630 mm
Width	1110 mm
Height	1924 / 2124 / 2324 / 2524 mm
Weight	1475 / 1505 / 1535 / 1565 kg

MEASURING RANGE

Longitudinal axis X (Ø)	-100 to 530 / 830 / 1030 mm
Optional X (Ø)	-220 to 410 / 710 / 910 mm
Transverse axis Z	600 / 800 / 1000 / 1200 mm

KENOVA set line V9xx-S

Technical data

EQUIPMENT DIMENSIONS with TUL rack V

Length	3050 mm
Width	1350 mm
Height	1924 / 2124 mm
Weight	1648 / 1678 kg

MEASURING RANGE

Longitudinal axis X (Ø)	-100 to 530 mm*
Optional X (Ø)	-220 to 410 mm
Transverse axis Z	600 / 800 mm

* max. Ø 440 mm pivotable due to shrink fit equipment

Front view

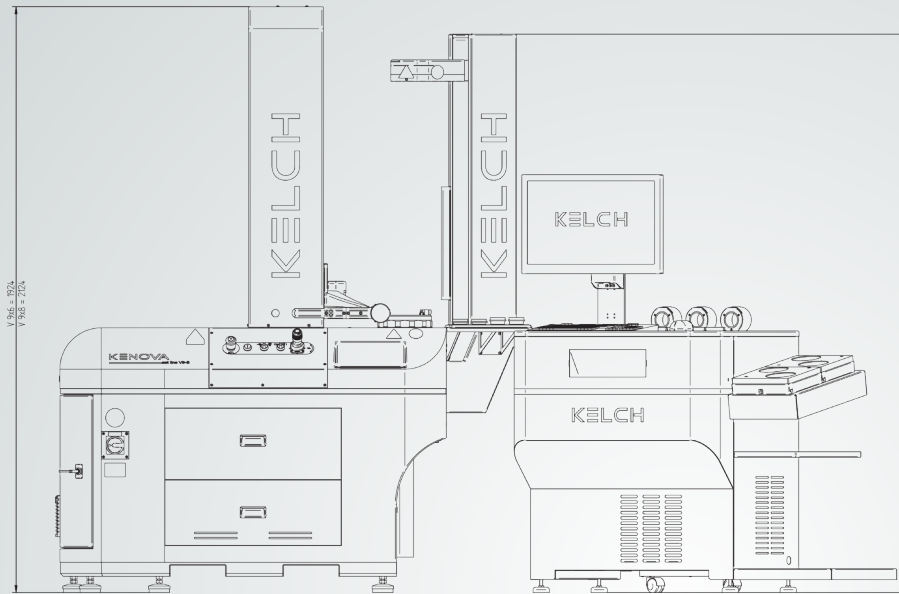

Side view

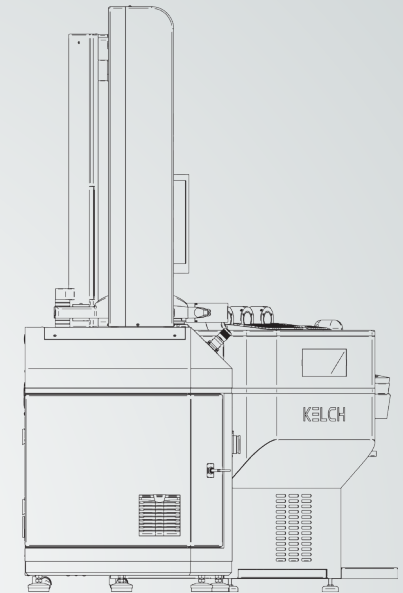

Top view

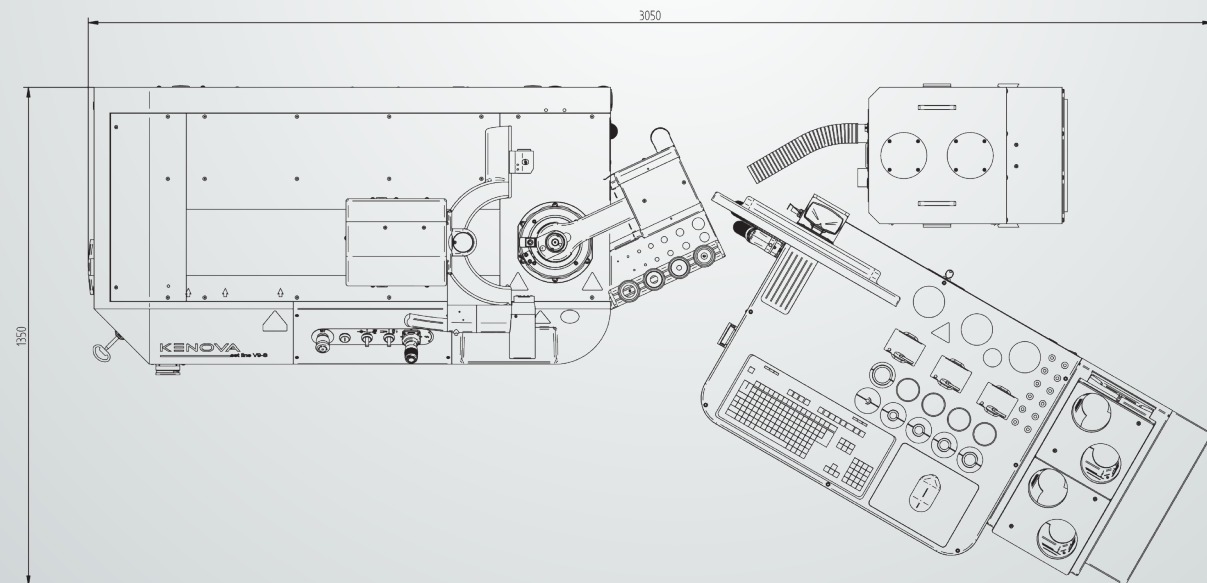



www.kelch.de

KELCH



Germany

KELCH GmbH

Werkstraße 30
71384 Weinstadt

Phone: +49 (0) 71 51 / 205 22 - 0
Fax: +49 (0) 71 51 / 205 22 - 11

info@kelchgmbh.de
www.kelch.de

China

Harbin Measuring &
Cutting Tool Group Co., Ltd.

44 Heping Road
Harbin 150040

Phone: +86 451 86 79 26 95
Fax: +86 451 82 62 35 55

links@links-china.com
www.links-china.com

USA

KELCH Inc.

600 Albion Avenue
Schaumburg, IL 60193

Phone: +1 847 459-9600
Fax: +1 847 459-9629

info@kelch-inc.com
www.kelch-inc.com

No responsibility is accepted for the accuracy of this information or these illustrations. Subject to engineering and design changes.